

AUTOMOBILES
CITROËN

AFTER-SALES TECHNICAL DIVISION

The enclosed schedule deals with particular points concerning the overhauling of a MASERATI engine in an SM vehicle.

These particular points are taken from WORKSHOP MANUAL 581-3.

This schedule contains 29 cards which can be used as "workshop index cards"

These may be protected with plastic sleeves.

Place the cards in the proximity of the work-bench where the overhaul of components is carried out so that the mechanic can use them for reference.



INFORMATION
BULLETIN

N° 1 S

20th April 1972

CONFIDENTIAL
(all rights reserved)

Property of:
John Titus

SM VEHICLES
(SB series SB)

ENGINE

OVERHAULING
THE
ENGINE

DISMANTLING

PARTICULAR POINTS ON DISMANTLING AND ASSEMBLY

1

- Raise the engine using the lifting attachments
- Remove :
 - The engine mountings
 - The starter motor
- Use the sling 2517-T

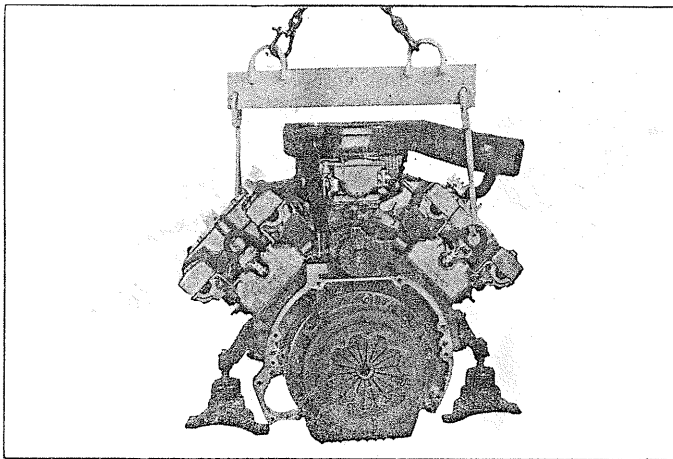

2

- Fix the engine on the dismantling support
 - Stand 2509-T
 - Adaptor 2512-T

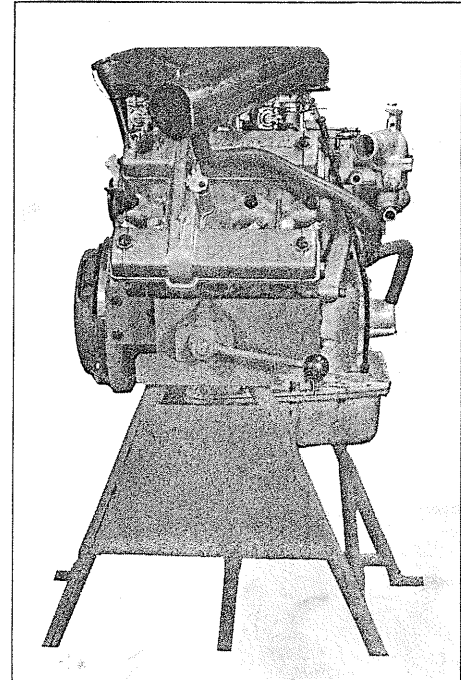

3

- Remove
- The air filter
 - The circlips(3) of the accelerator control knuckle
 - The air-intake horns
 - The base of the filter (1)
 - The carburettor/manifold assembly (screw 2).

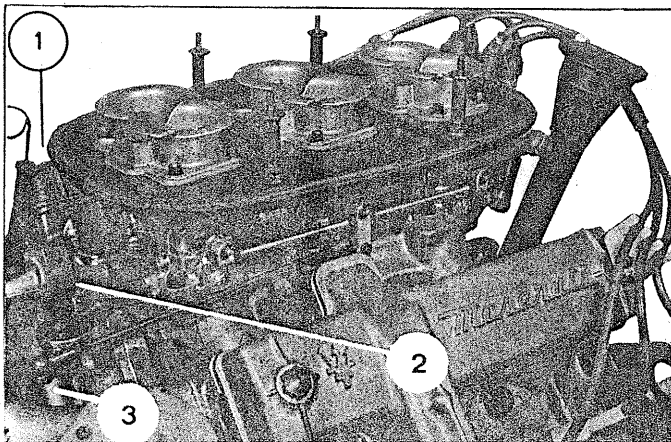

4

REMOVE THE OIL FILTER

Strap wrench

e.g. FACOM D. 46

Spanner

MR. 630-14/49

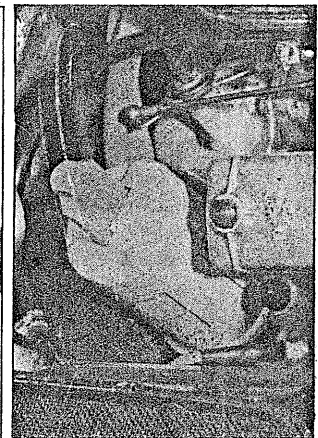

DISMANTLING Contd.

5

Remove the mechanism and the clutch disc

Remove the fly-wheel

Tool E from the set 3064-T

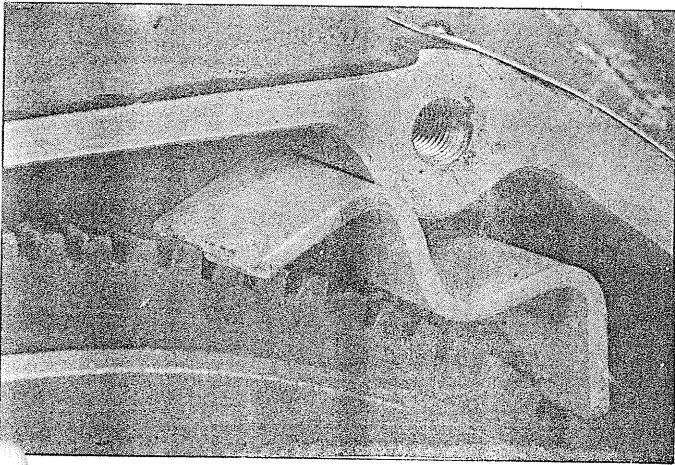

6

Remove the manifold :

- Collar (1)

- Screw (2)

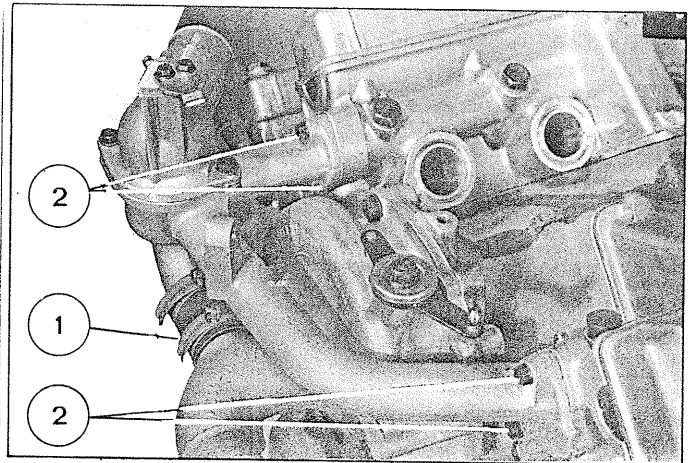

7

REMOVING THE CYLINDER-HEADS

- Turn the engine to bring the spring links to the top
- Loosen the chains by slackening the nuts (1)
- Remove the spring links
- Disengage the chains from the "exhaust" camshaft pinions.

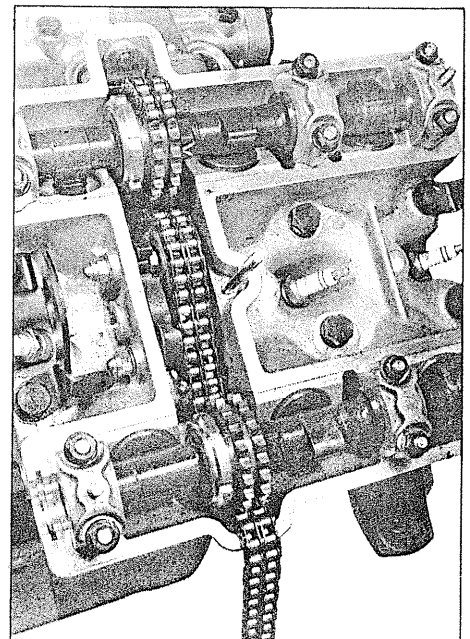
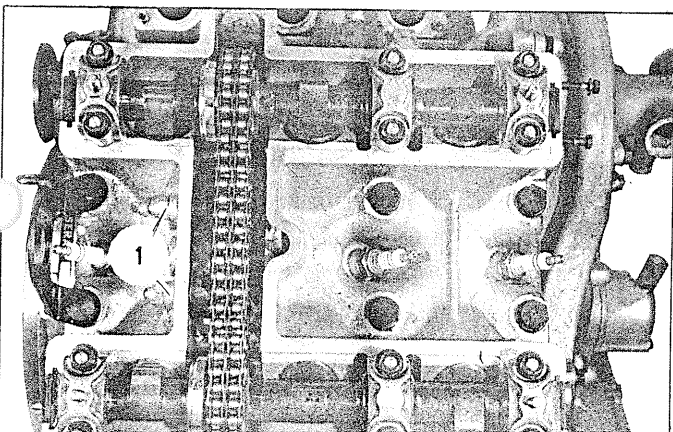

DISMANTLING Contd.

PARTICULAR POINTS ON DISMANTLING AND ASSEMBLY

7 Contd.

- Remove the screw at position "a".
- Swivel the tensioner towards the bottom.
- Disengage the screw (1) of the tensioner.
- Remove the chain tensioner
- Remove the cylinder heads (screws 2)

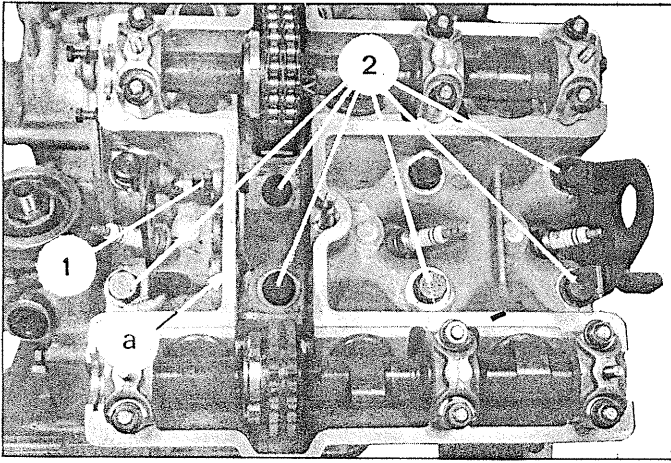
**8**

- Remove the water pump cover (screw 1)

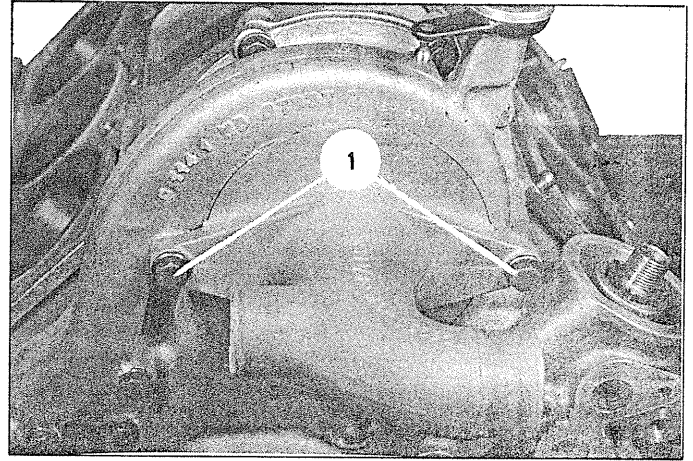
**8** Contd.

Removing the water pump

- Unlock the nut (2) and remove it.
- Remove the turbine (be careful with the cotter).

- Remove the sealing ring of the pump shaft.

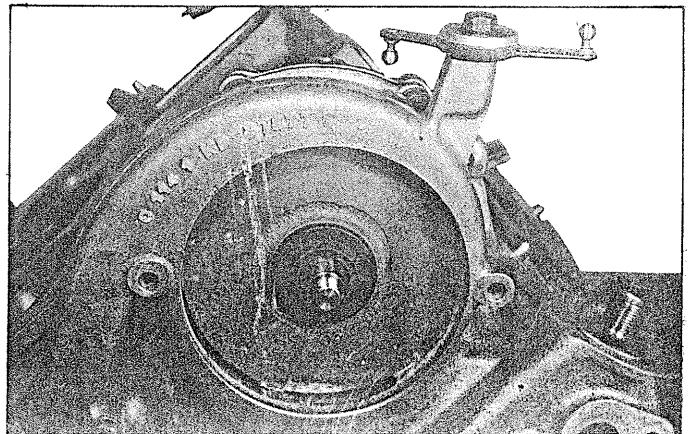
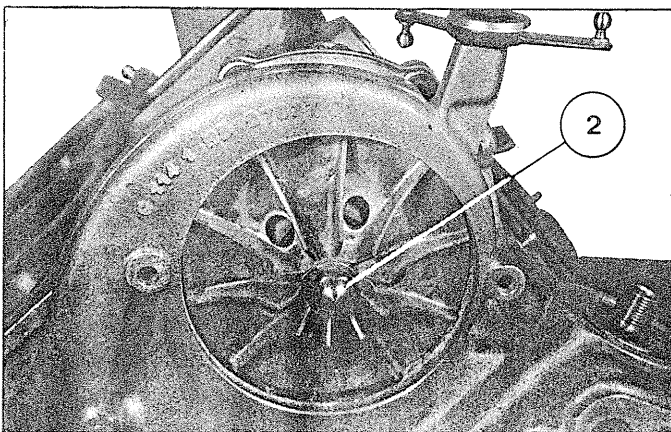

DISMANTLING Contd.

9

- Remove the oil sump

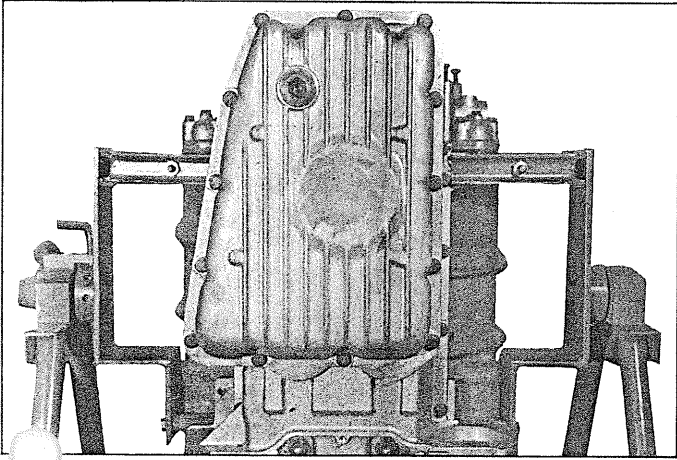

10

- Remove the oil pump filter

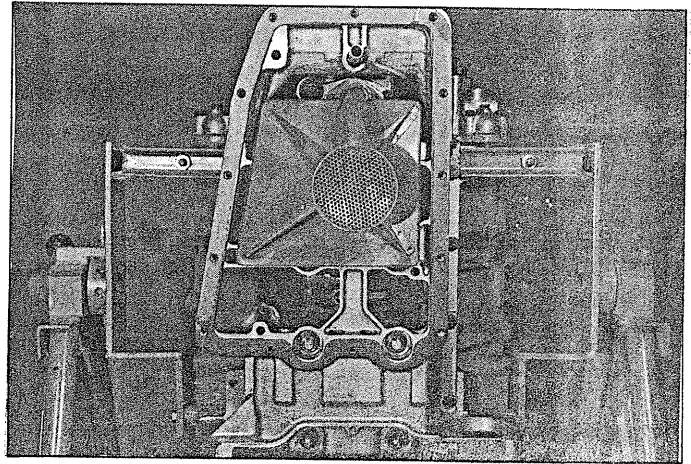

11

- Remove the timing case

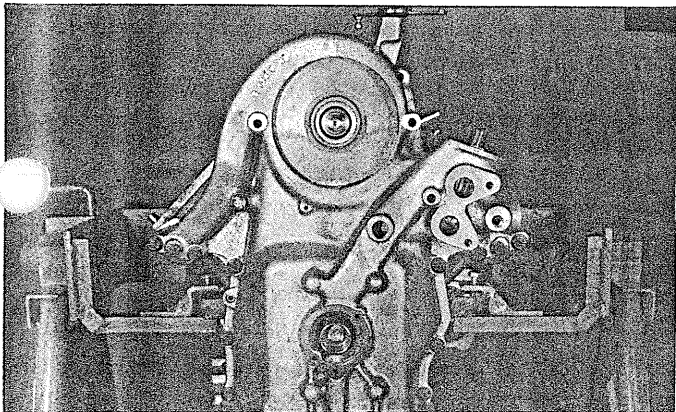

12

- Disengage the chain tensioner :
Using a screwdriver apply pressure to the lug (1) and turn the spindle (2) a quarter of a turn.
- Remove the chain guide and the tensioner (take care with the flat washers between the tensioner and the housing).

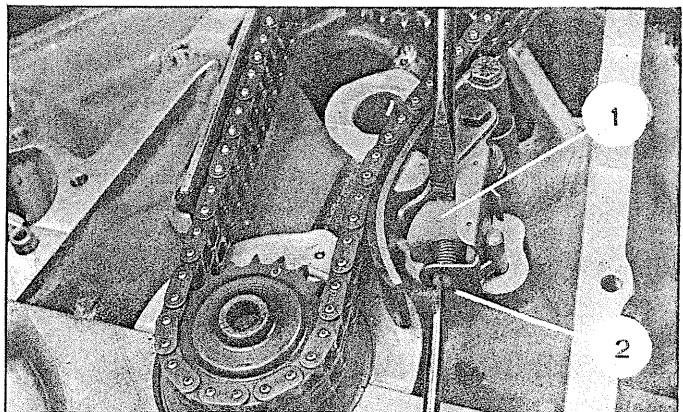

DISMANTLING Contd.

PARTICULAR POINTS ON DISMANTLING AND ASSEMBLY

13

REMOVING THE INTERMEDIATE TIMING SHAFT

Remove the driving flange from the H.P. pump control shaft.

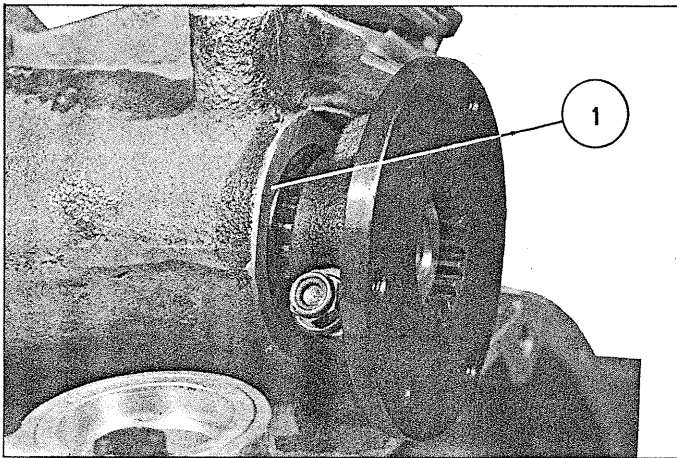

Disengage the intermediate timing shaft

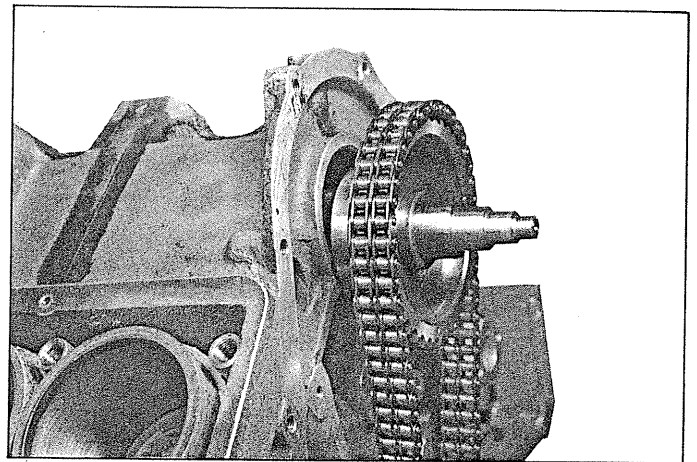

13 Contd.

- Disengage the timing chain between the housing and the pinion.
- Remove the intermediate timing shaft.
- Disengage the chain
- Remove the sealing ring (1)
(extractor tube $\phi = 39$ mm, length = 400 mm)

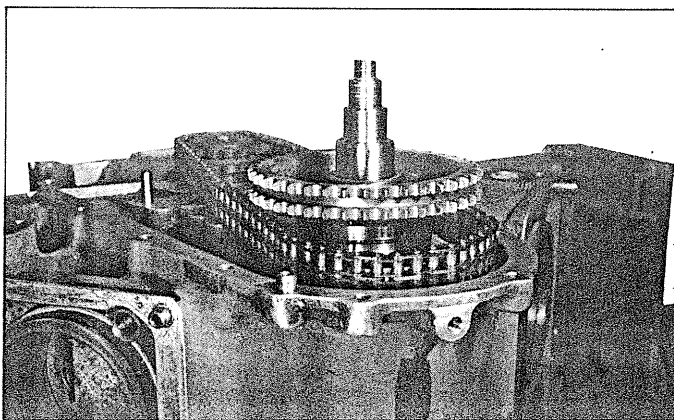

14

Remove the lower housing and its gasket.

N.B. : This housing is held by
8 dowels

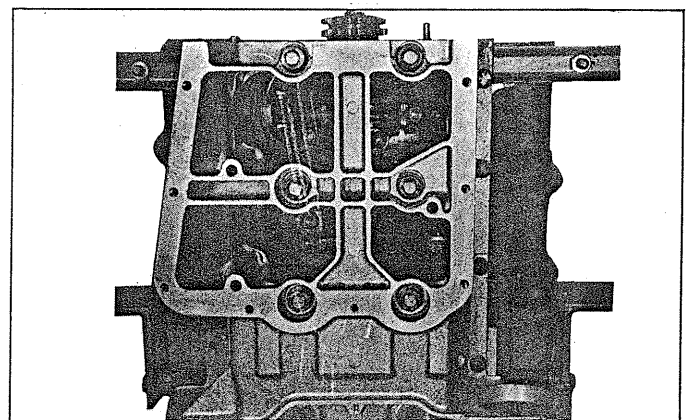

DISMANTLING Contd.

15

- Remove the con rod caps (socket of 14 mm and adaptor of 3/8").

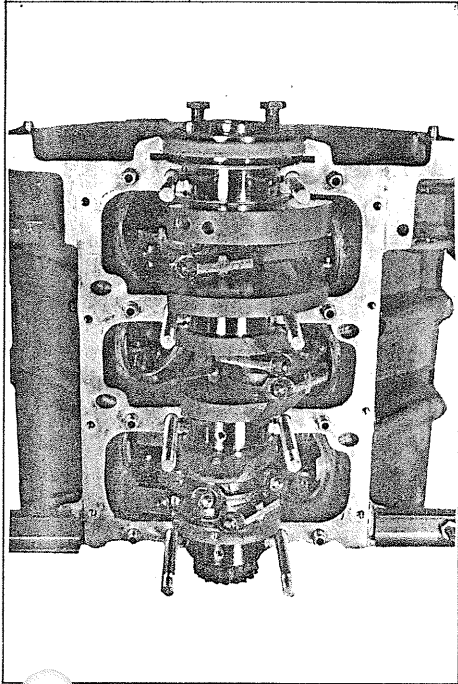

- Remove the crankshaft
- Remove the con rod piston assemblies

16

- Remove :
- The crankshaft bearing shells
- The end float adjusting shims.

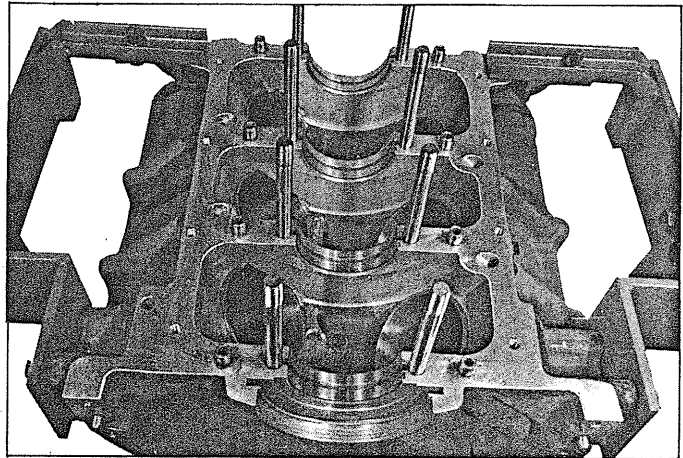

16 Contd.

CLEANING

Carefully clean all the parts and the joint surfaces.

Blow with compressed air.

NOTE : Alcohol should be used to remove CURTYLON.

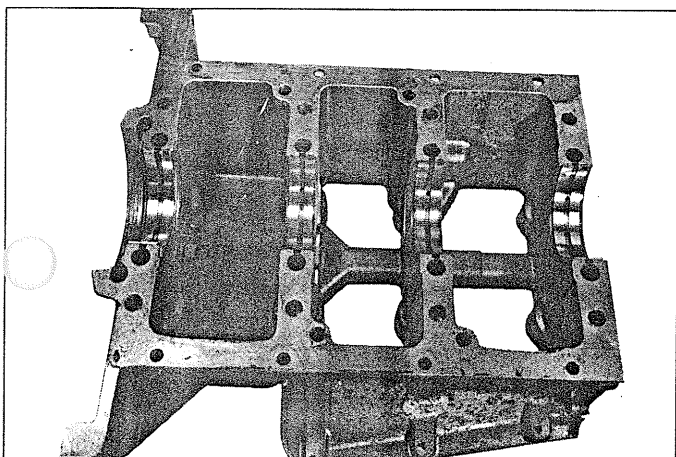

DISMANTLING Contd.

PARTICULAR POINTS ON DISMANTLING AND ASSEMBLY

17

WORK ON THE CON ROD PISTON ASSEMBLIES

Remove the rings

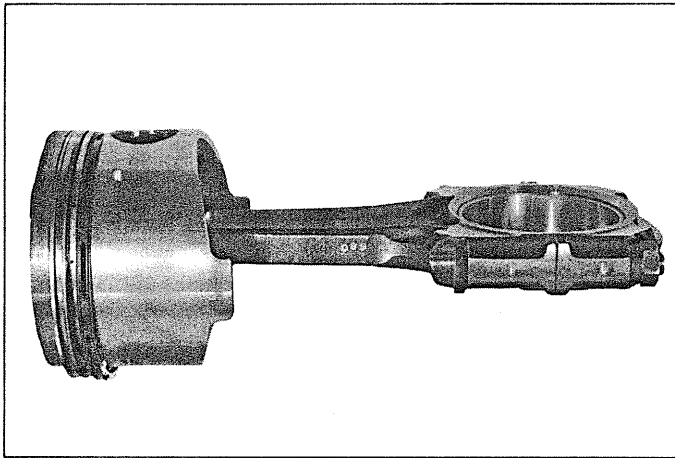
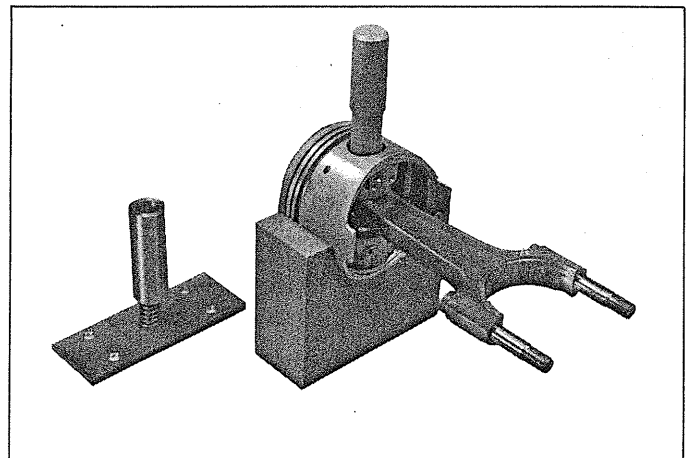
Remove the gudgeon pin
Tool G from the set 3064 - T

18

STRIPPING THE CYLINDER-HEADS

Remove :

- The sparking plugs
- The camshafts

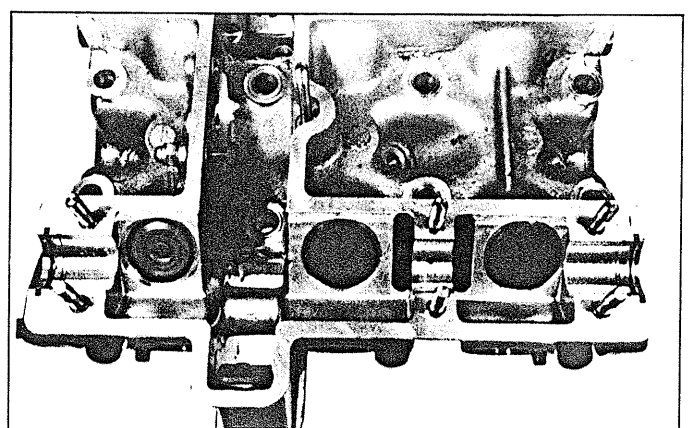
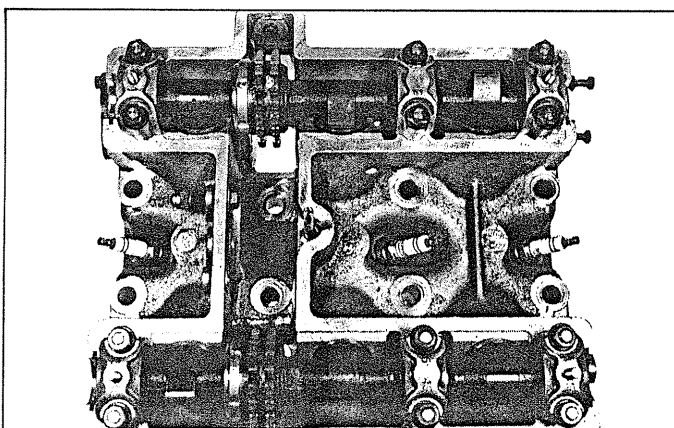
Remove the valve push rods and the capsules
for adjusting the clearance, marking their
respective positions.

DISMANTLING Contd.

8 Contd.

Remove the free-play limiter of the chain.

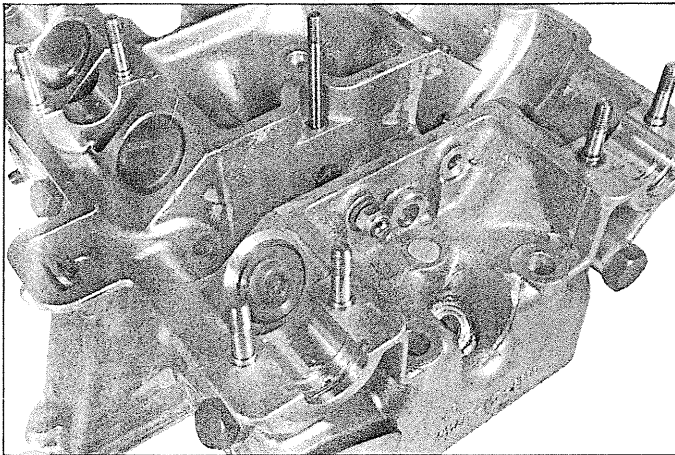

Remove the valves
(universal compressor and tool D from the set 3064-T)

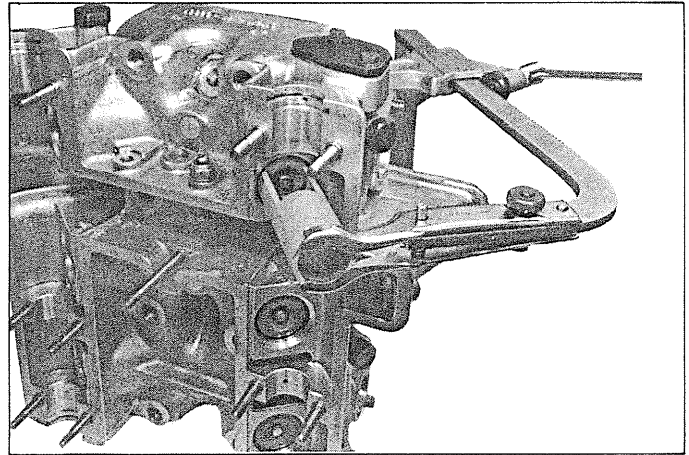

8 Contd.

- Grind the seatings and the valves (grindstone 1630-T)
- Width of the bearing faces of the seatings
- Inlet : 2.5 mm
- Outlet : 2.2 mm

- Grind the valves in.
After grinding in, clean the parts carefully and blow them with compressed air in order to eliminate all trace of abrasive materials.

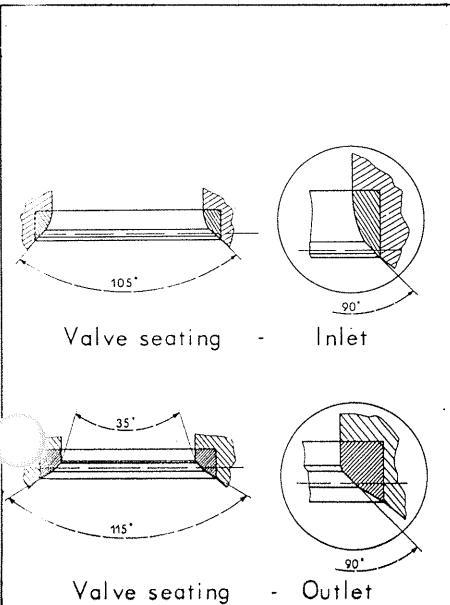

Stripping the timing case
Remove :

- The oil pump
- The gasket (1) (tube spanner ϕ : 33 mm length : 100 mm)
- The accelerator control return lever (4)
- The plug (2)
- The union (3) and the by-pass valve (if necessary).

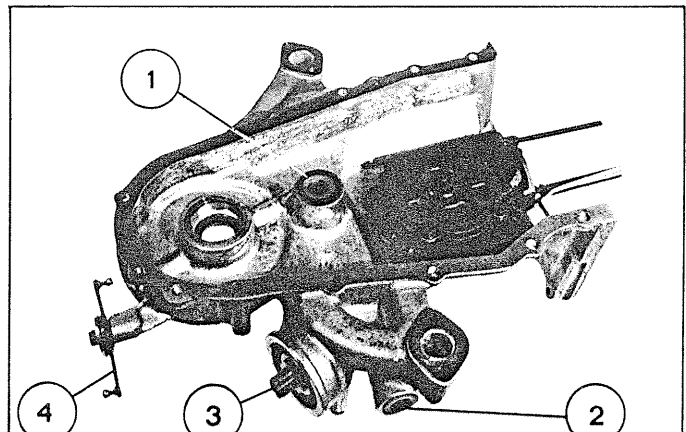

ASSEMBLY

PARTICULAR POINTS ON DISMANTLING AND ASSEMBLY

IMPORTANT NOTES

GASKETS

ALL gaskets must be systematically renewed

All gaskets should be fitted greased with tallow (except the **REINZ** cylinder-head gaskets which must be fitted dry).

TIGHTENING TORQUES

On this engine, all tightening torques **MUST** be respected.

Failure to do this results in deformation which adversely affects the correct running of the engine.

NOTE : Nuts and bolts must be fitted with their threads oiled.

Check how far the barrels are recessed.

- 1) In relation to the joint face of the cylinder casing :
0.02 - 0.05 mm.
- 2) Amongst themselves, the barrels should be in the same plane to within : 0.02 mm.
Straight edge 1698-T + foil. Correct if necessary with tool A from set 3064 - T

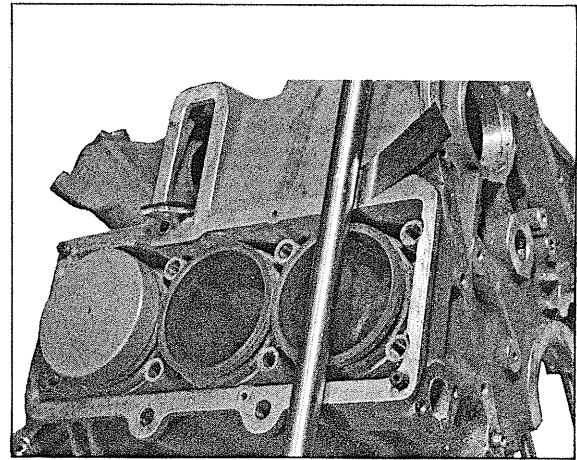

20

PREPARING THE PISTON/CON ROD ASSEMBLIES

- When assembling the pistons and con rods, the chamfer C should be on the same side as the longer slope L.

- Heat the con rod to 200° - 250°C (392-482°F) (oven).

- Position the con rod in the piston (guide of assembly G of set 3064-T)

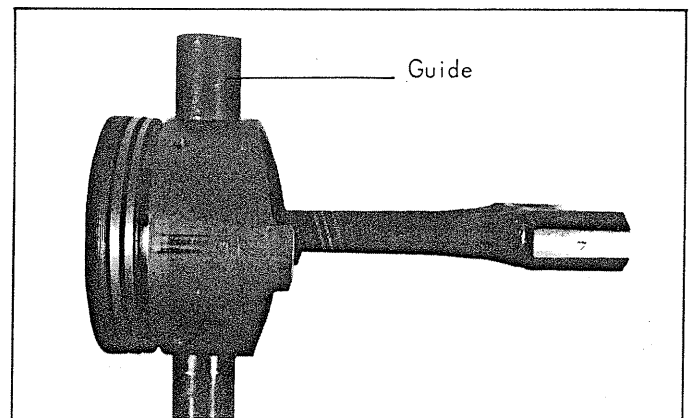
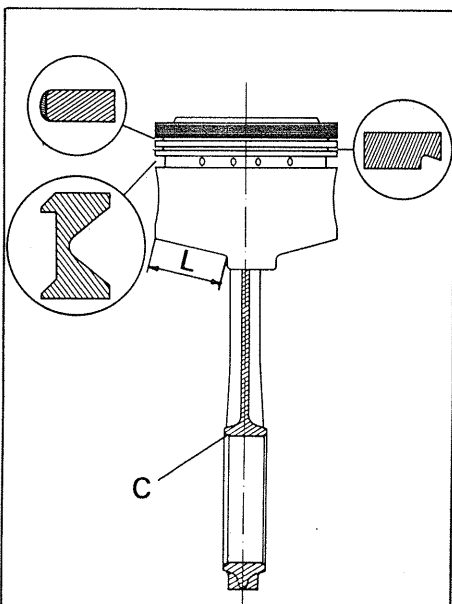

ASSEMBLY Contd.

20 Contd.

- Place the piston/con rod assembly on the support of assembly G, set 3064-T.
- Fit the spindle in place (press and mandrel of assembly G, set 3064-T).
- Fit the rings.
 - a) Oil control ring (2) - gap : 0.25 - 0.40 mm - "TOP" mark at the top
 - b) Scraper ring (1) - gap, 0.30-0.45 mm - "TOP" mark at the top
 - c) Compression ring (3) - gap : 0.35 - 0.45 - unmarked

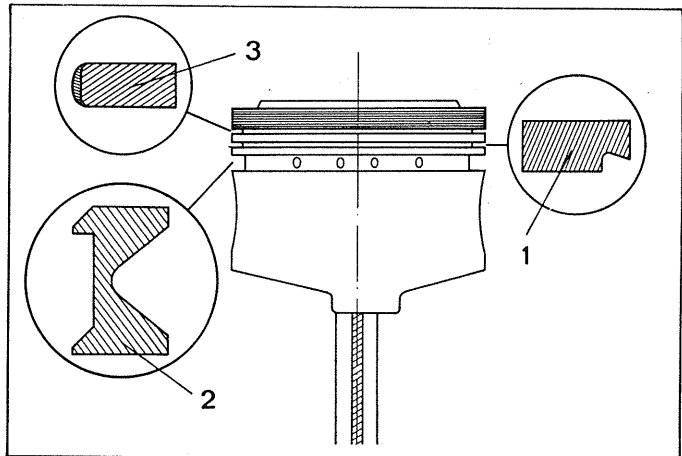
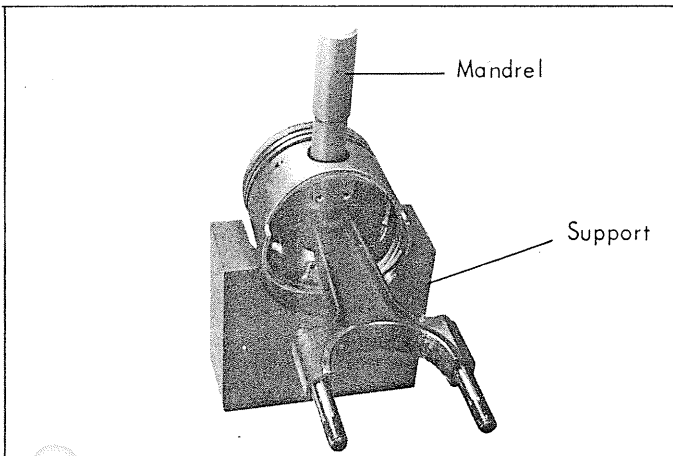

21

- Fix the engine casing on the support
- Fit the half bearings in the casing

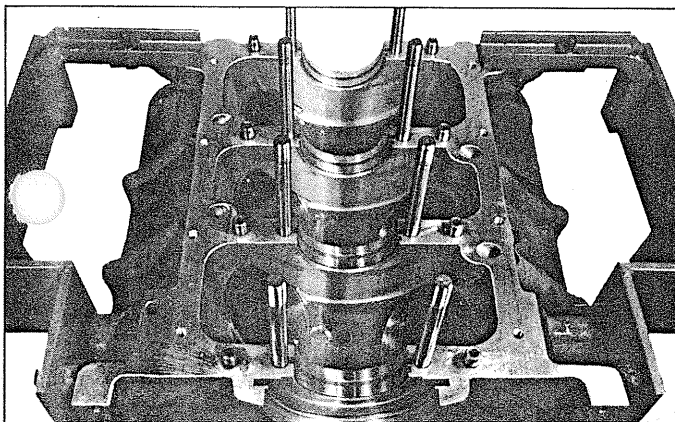

22

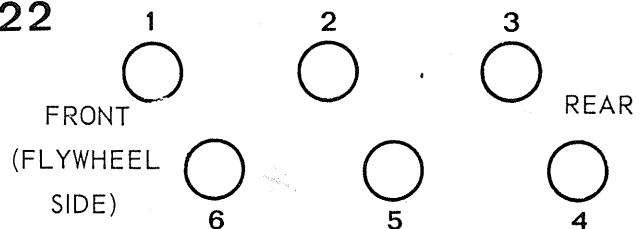

For con rods 1,2,3, chamfer C towards front
 For con rods 4,5,6, chamfer C towards rear

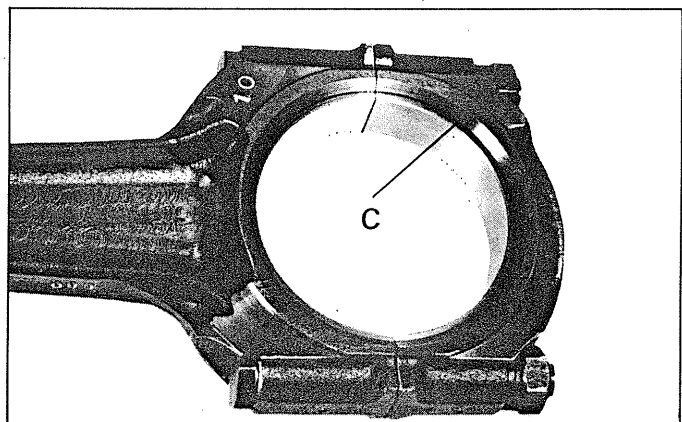

ASSEMBLY Contd.

PARTICULAR POINTS ON DISMANTLING AND ASSEMBLY

22 Contd.

FITTING THE ENGINE HARNESS

- Offer up the crankshaft. Hold it above the bearings (plates F of set 3064- T in order to avoid damaging the half bearings whose interior diameter, in a free state, is smaller than the diameter of the crankshaft pin).
- Fit the piston/con rod assemblies (normal ring fitting collar) in the order 1-6, 2-5, 3-4 tighten to 68 mAN (6.8 m.kg 49 ft/lbs) socket 14 + reducer 3/8"
- Withdraw the plates and lower the crankshaft onto its bearings.
- Fit the bearing half shells (without tongue) : clearance 0.15-0.22 mm : the oil reserves should be on the crankshaft side.

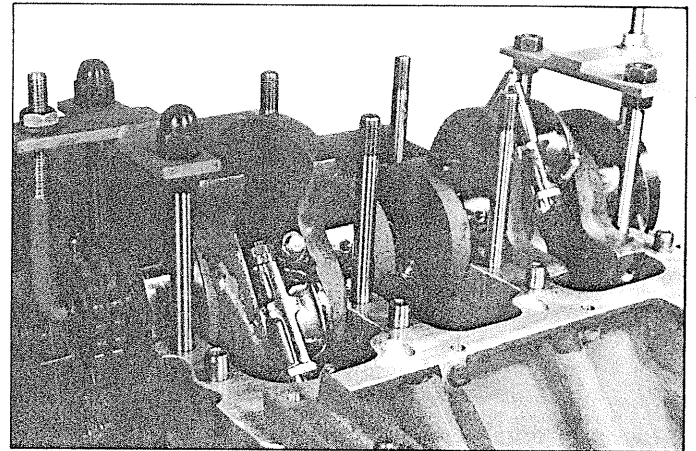
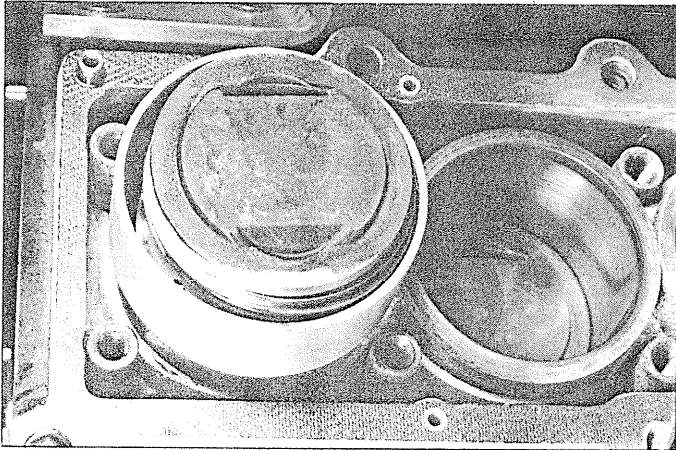
**23**

FITTING THE SUMP

- Fit the half-bearings : the half shells (tongued), stuck together with grease.
- Coat the surface of the gasket with CURTYLON
- Fit the sump half and tighten the nuts A of the bearing to 95 - 97 mAN (9.5-9.7 m.kg, 68-69 ft/lbs). Observe the tightening sequence.
- Tighten the bolts (B) to 15-20 mAN (1.5-2 m.kg. 10.8-14.4 ft/lbs).

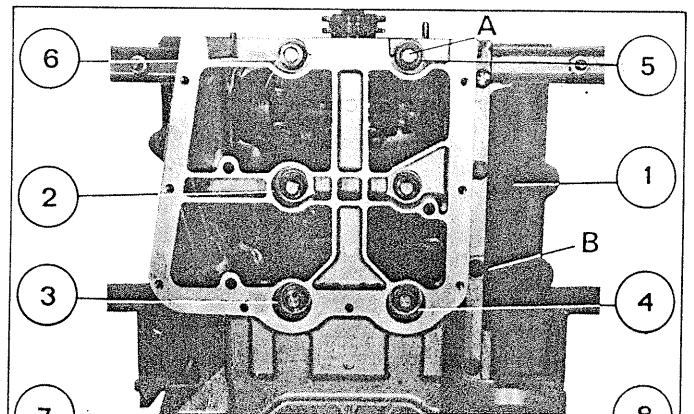
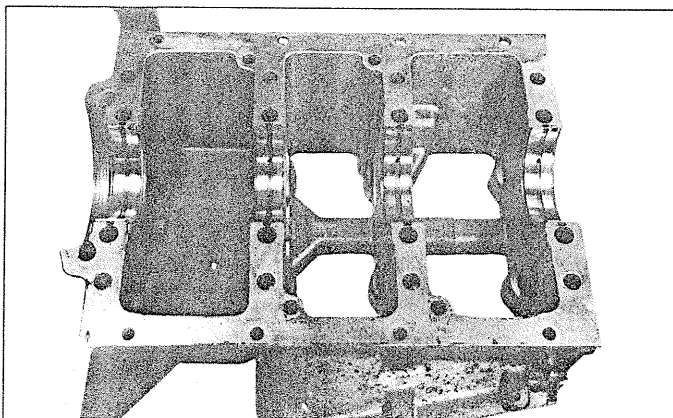

ASSEMBLY Contd.

24

FITTING AN OIL SEAL

(Orange-coloured gasket with micro-turbine on lip)

- Lightly grease the lip of the seal
- Fit the seal. Tool MR. 630-34/32

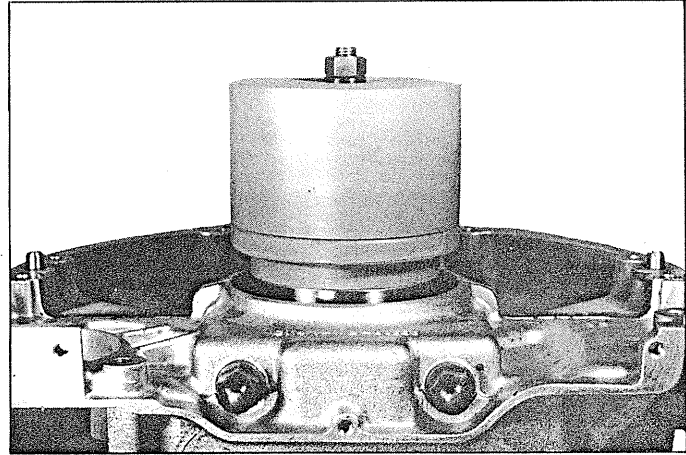
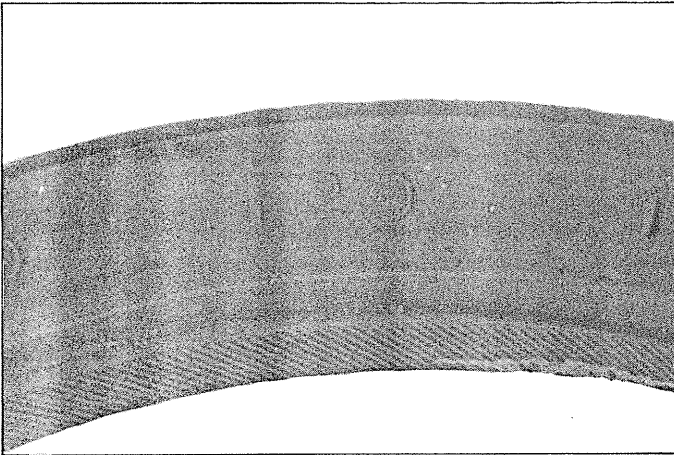

25

- Fit the engine flywheel
- Tighten the bolts : 120 mAN (12 m.kg, 86 ft/lbs)
- Immobilize the flywheel. Tool E of set 3064-T.

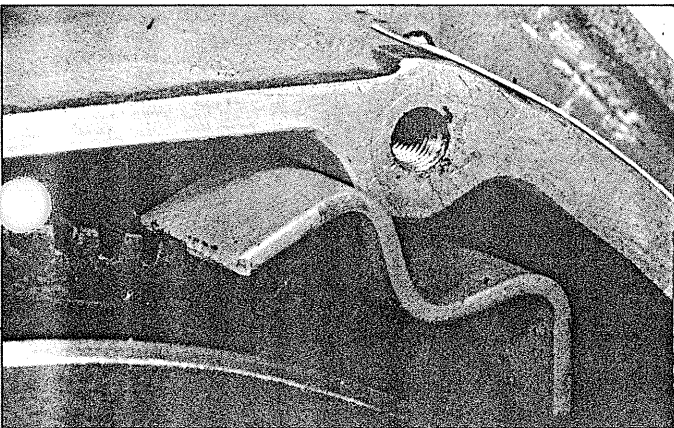

26

- Bring the marks on the crankshaft and the housing into line.
- Fit the control chain of the intermediate shaft on the pinion.

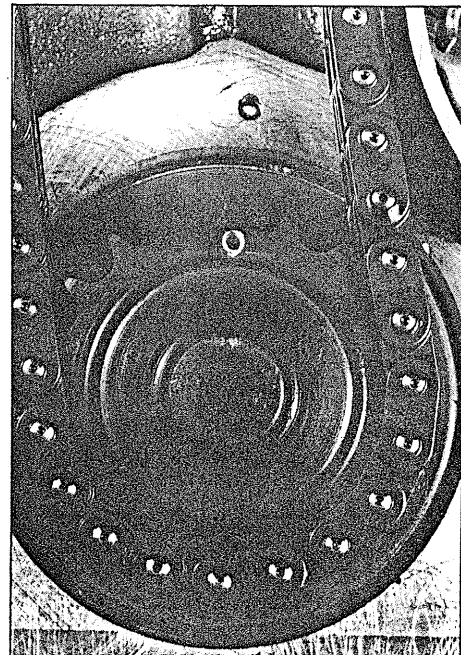

ASSEMBLY Contd.

PARTICULAR POINTS ON DISMANTLING AND ASSEMBLY

26 Contd.

FITTING AND ADJUSTING THE INTERMEDIATE TIMING SHAFT

- Position the control chain (see photo)
- Fit the intermediate shaft.
 - a) Bring the marks on the pinion and the housing into line.
 - b) The marks (1) should be visible in the timing chain passage.

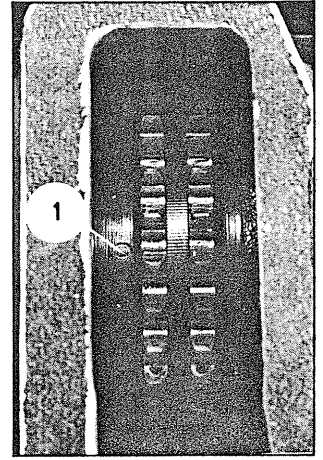
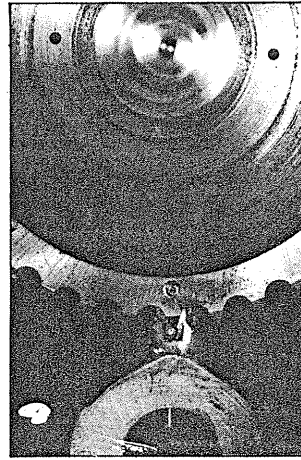
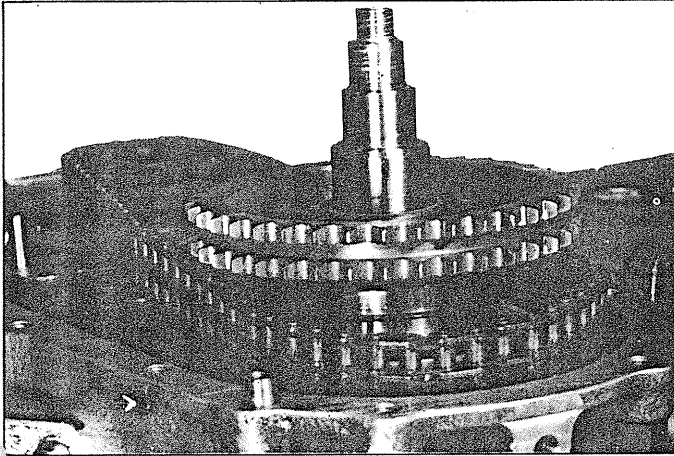
**26** Contd.

Engage the chain on the control pinion.

Engage the intermediate shaft on the bearings.

Fit the tensioner (2) (washer between tensioner and housing)

Tighten to 10-12 mAN (1-1.2 m.kg 7.2-8.7 ft/lbs)

Fit the runner (3) (washer between runner and housing).

Tighten to 9-11 mAN (0.9-1.1 m.kg 6.5-8 ft/lbs)

Set the chain tensioner.

Fit the free play limiter (4) Clearance of ; 0.2 mm between limiter and chain.

Tighten to 9-11 mAN (0.9-1.1 m.kg 6.5-8 ft/lbs)

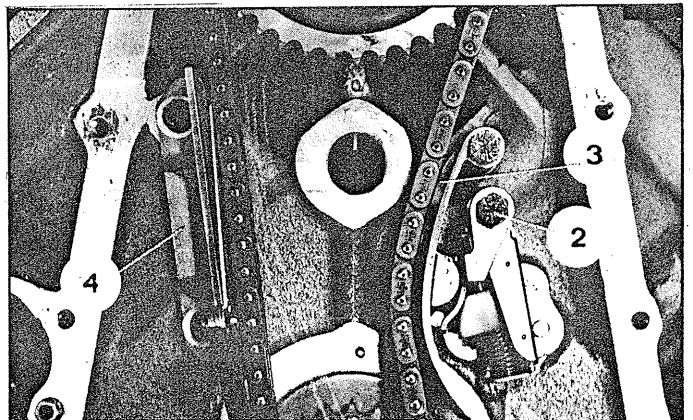
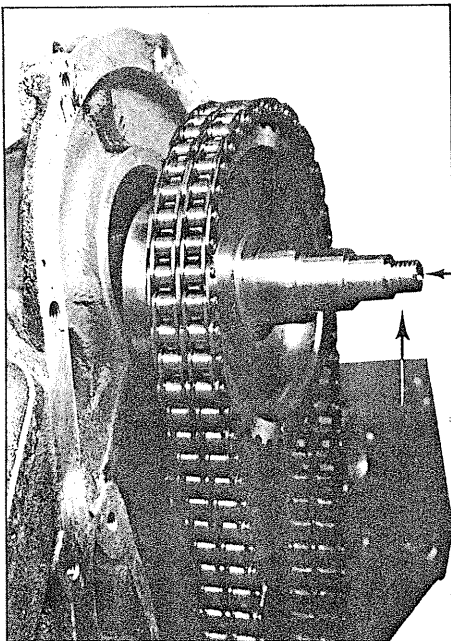

ASSEMBLY Contd.

27

PREPARING THE OIL PUMP

Fit on the body of the pump :

- The piston (10), the spring (9) and the return pipe (8), the adjusting washer (6) and the copper gasket (7). Tighten to 30 mAN (3 m.kg 22 ft/lbs)
- The ring seals (1) (2) and (11). Grease before fitting.
- The wheel (4), the pinion (3).
- The pump cover (5).
- Tighten the bolts (12) to 18-20 mAN (1.8-2 m.kg. 13-14.4 ft/lbs)

NOTE : It is essential to fit a piston with a shoulder at « a ».

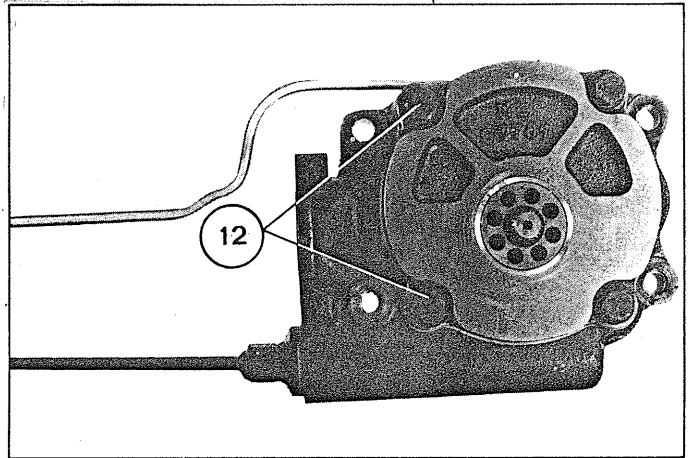
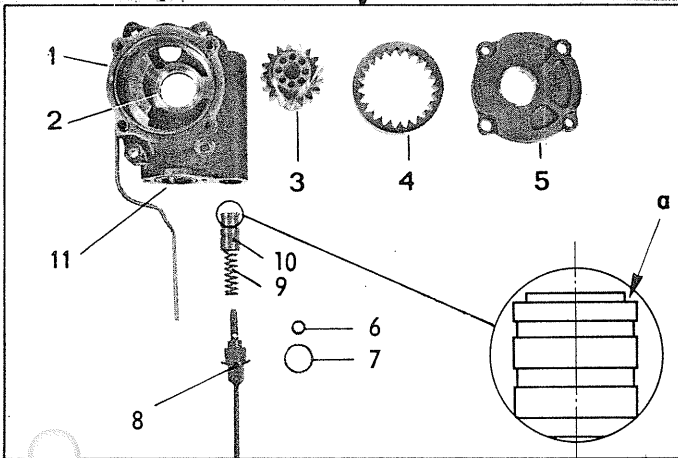

28

PREPARING THE TIMING CASE

- Fit the by-pass valve. Screw the valve into the case.
- Fit the oil filter union (4) : 90-100 mAN (9-10 m.kg 65-72 ft/lbs).
- Fit the oil seal (2) in place (mandrel $\phi = 36$ mm, length = 100 mm).
- Fit the accelerator control return lever (3).
- Tighten the nut to : 25-27 mAN (2.5-2.7 m.kg 18.1-19.5 ft/lbs).

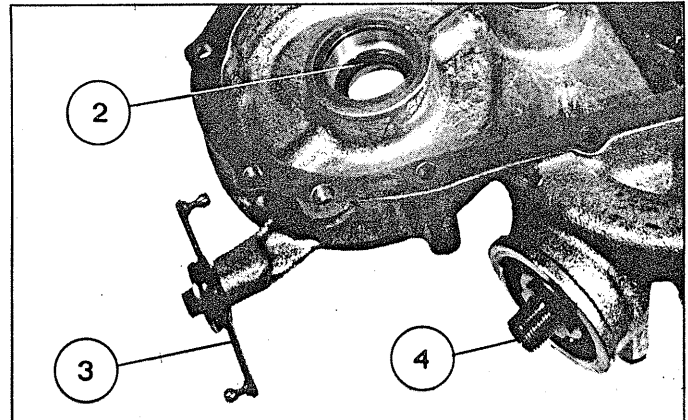
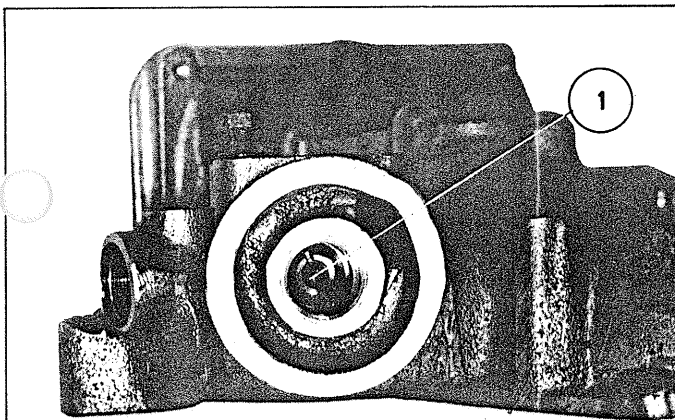

ASSEMBLY Contd.

PARTICULAR POINTS ON DISMANTLING AND ASSEMBLY

28 Contd.

- Fit the plug (6), tighten to 70 mAN (7 m.kg 51 ft/lbs)
- Fit the oil pump : take care in positioning the ring seal : 26-28 mAN (2.6-2.8 m.kg 19-20.3 ft/lbs)
- Fit the ring seal (5) in place.
- Hold the pipe (7) against the return pipe using a ring.

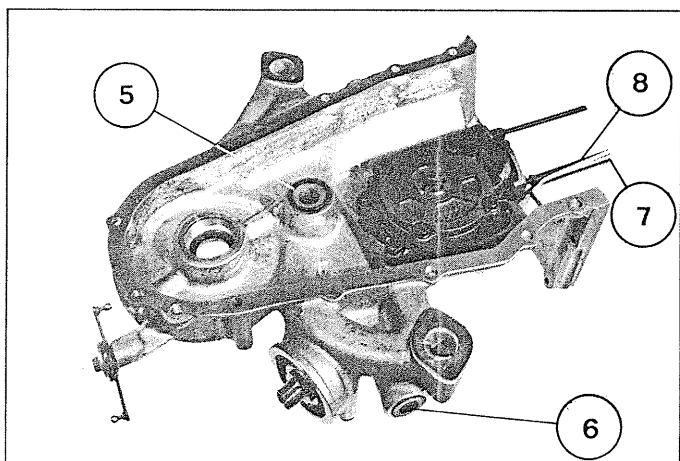
**29**

FITTING THE TIMING CASE

- Fit the cone (B) of the set 3064-T on the end of the intermediate shaft..
- Fit the pump drive shaft (1) (with a little grease)
- Fit the timing case. Turn the oil pump slightly to facilitate the engagement of the drive shaft.

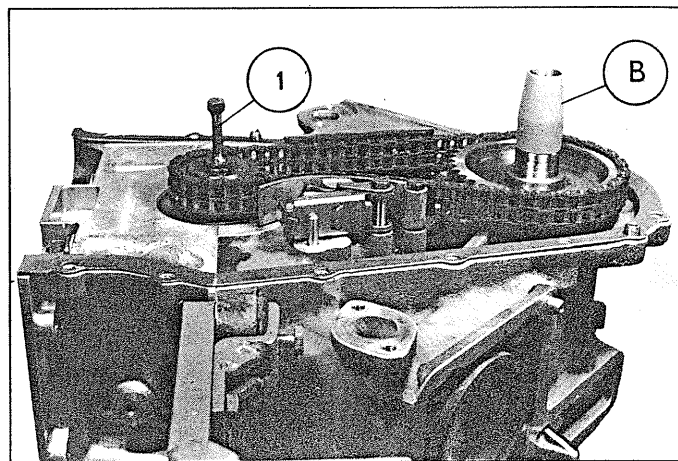
**29** Contd.

- Tighten the bolts (3) to 21-23 mAN (2.1-2.3 m.kg 15.2 - 16.6 ft/lbs)

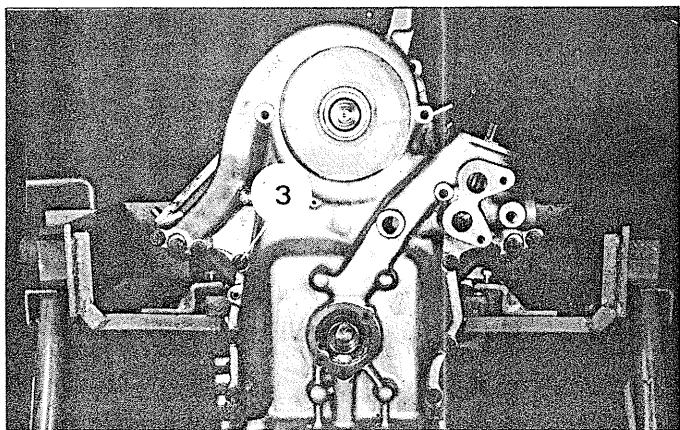
**30**

- Fit the breather (gasket)
- Tighten the bolts : 10 mAN (1 m.kg 7.2 ft/lbs).

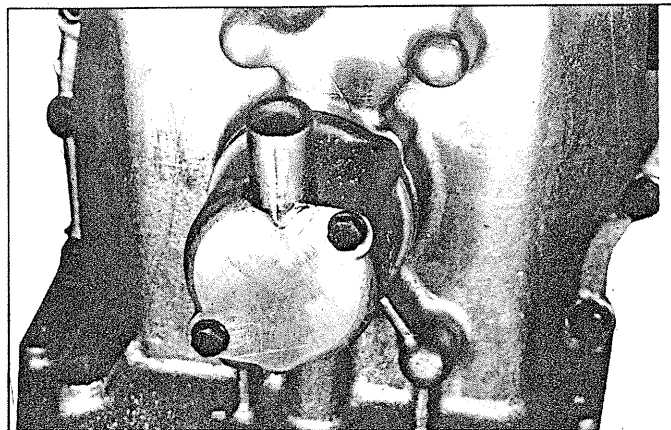

ASSEMBLY Contd.

31

- Fit the housing connecting the oil cooler.
- Tighten the bolts : 20 mAN (2 m.kg 14.4 ft/lbs)
- Fit the oil temperature thermal switch (1) : 30-35 mAN (3-3.5 m.kg, 22-25 ft/lbs)
- Fit the oil pressure switch (2) : 30-35 mAN (3-3.5 m.kg 22-25 ft/lbs).

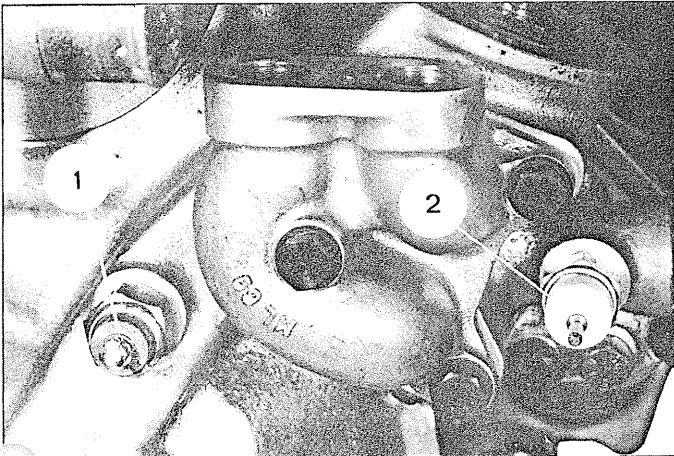
**32**

- Check the soldering of the suction tube/filter assembly.
- Fit the suction tube/filter assembly. Tighten the bolts (1): 10 mAN (1 m.kg 7.2 ft/lbs).
- Fit the oil basin (gasket) : take care with the shutters of the anti-emulsion partitions.

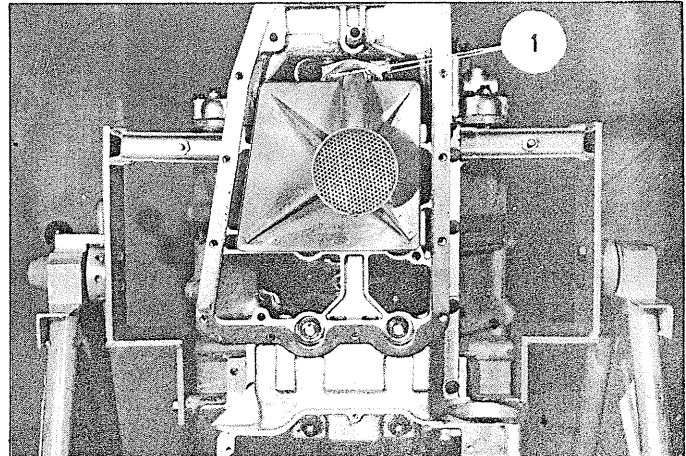
**32** Contd.

Tighten the bolts (2) : 16-18 mAN
(1.6-1.8 m.kg 11.6-13 ft/lbs).

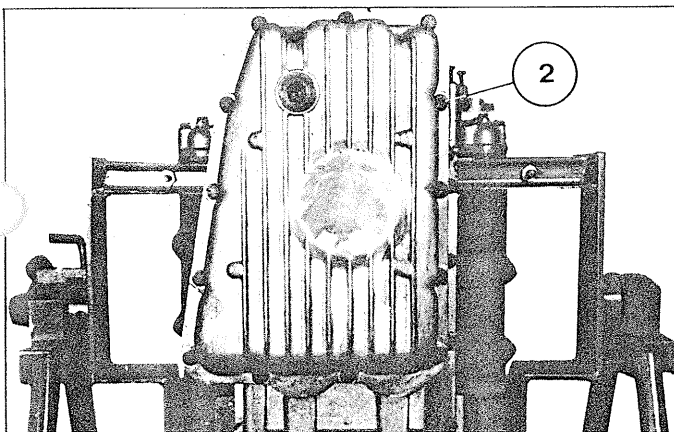
**33**

- Fit the intermediate shaft oil seal :
 tube spanner : int. $\phi = 30$ mm
 ext. $\phi = 45$ mm
 length. $\phi = 100$ mm

It should be level with the casing.

NOTE : To protect the lips of the gasket, wrap adhesive tape around the splines

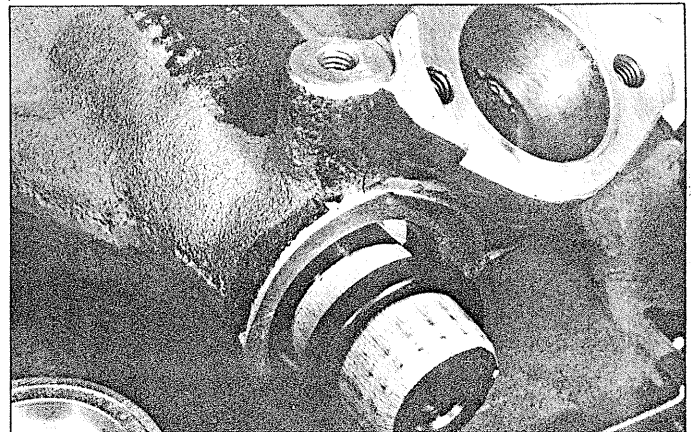

ASSEMBLY Contd.

PARTICULAR POINTS ON DISMANTLING AND ASSEMBLY

34

Fit the drive plate of the H.P. pump control shaft.

Fit the nut (1) but do not tighten.

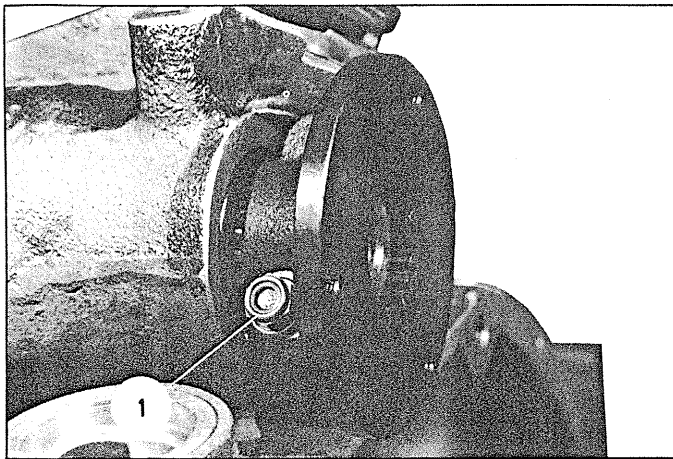

35

FITTING THE WATER PUMP

- Fit the oil seal (1) on the housing.
- Coat the thrust face (a) of the gasket and its contact surface on the turbine with Rocol A.S.P or MOLYKOTE 557 grease

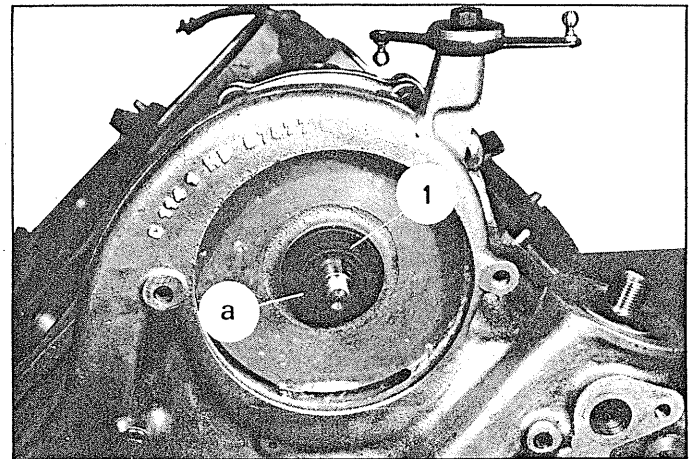

35 Contd.

Fit :

- The key
- The turbine
- The washer, the stop washer.
- The nut (thread coated with ADEXOLIN 56 glue)

Tighten the nut : 30 mAN (3 m.kg, 22 ft/lbs).

Fold down the stop washer locking lugs.

- Fit the cover (with its ring seal).
- Tighten the bolts : 20 mAN (2 m.kg 14.4 ft/lbs).

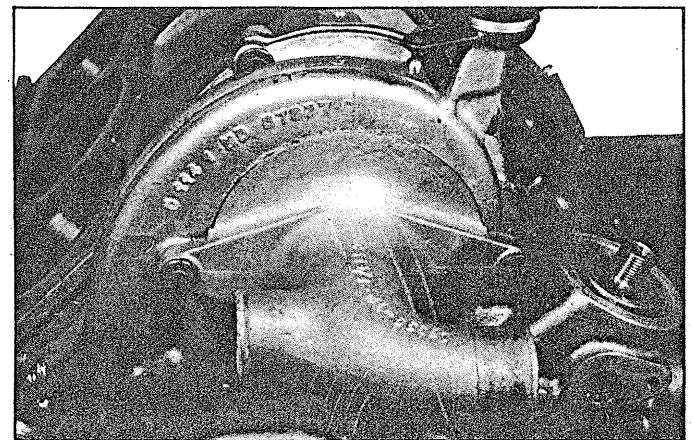
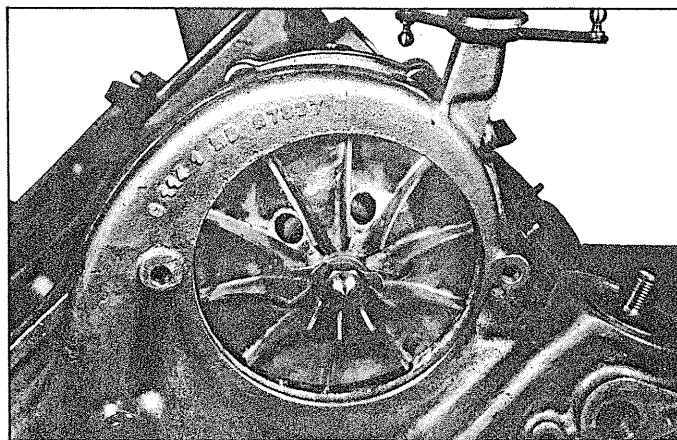

ASSEMBLY Contd.

36

CHECKING THE FLATNESS OF THE CYLINDER HEADS

- Check the flatness of the cylinder heads
Straight edge 1698-T and foil strips
Max out of flat = 0.05 mm.
- Minimum height after regrinding 110.2 mm.

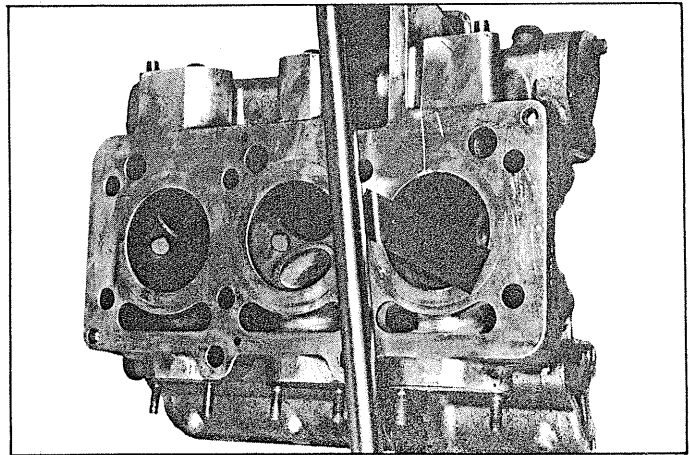
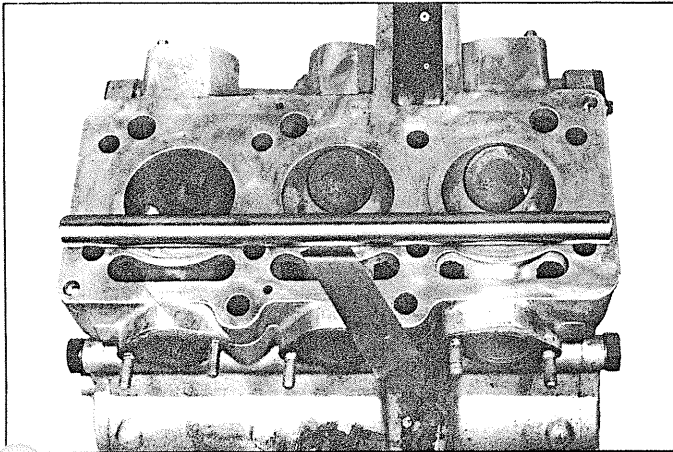

37

PREPARING THE CYLINDER HEADS

- Make sure that the ducts (1) and (2) and the jets for the camshaft lubricating oil are clean.

Fit :

- Valve stem oil seals (inlet only)
- The cups
- The springs

Universal compressor and tool D from set 3064-T.

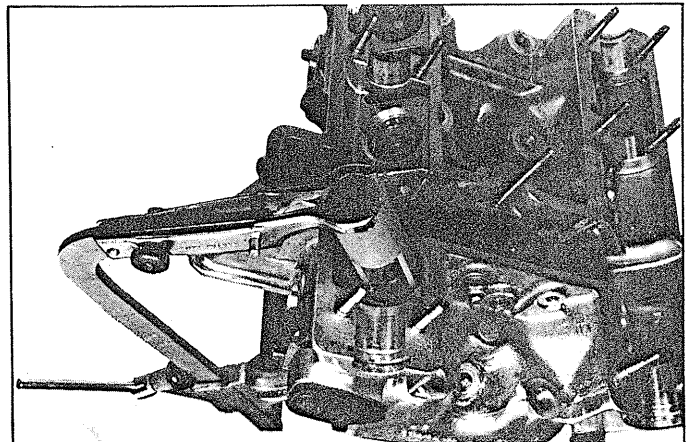
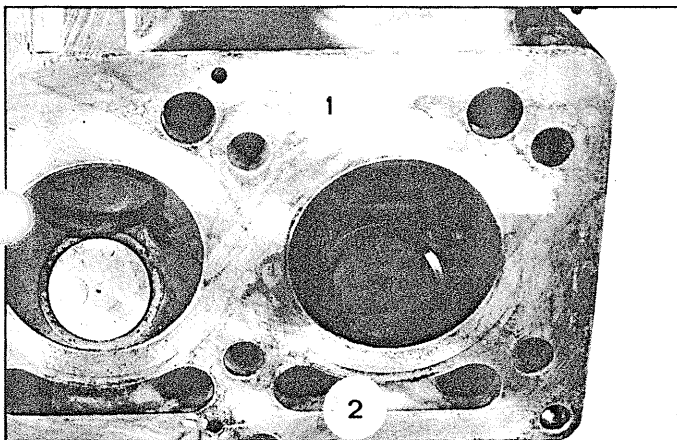

ASSEMBLY Contd.

PARTICULAR POINTS ON DISMANTLING AND ASSEMBLY PREPARATION OF THE CYLINDER HEADS

37 Contd.

- Fit the free play limiter (2) (bolts fitted with LOCTITE GX 01 460 01 A).
- Fit the capsules (1) and the push rods found when dismantling, back in their respective places.

- Fit the camshaft : inlet, (V), exhaust (1₁)
- Fit the caps of the camshaft bearings (marked by Nos).
- Tighten the nuts : 26-28 mAN (2 6-2.8 m kg 18,8-20,3 ft/lbs).

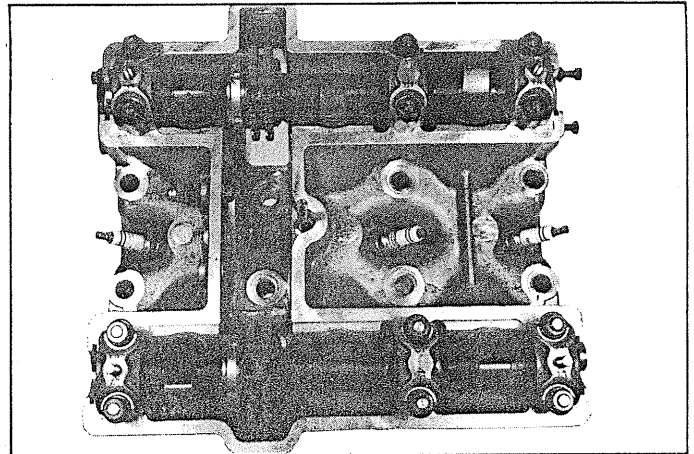
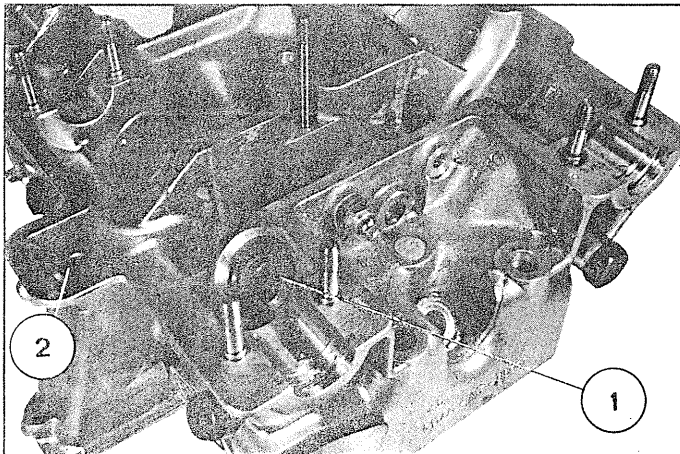

37 Contd.

- Turn the camshafts (spanner D from set 3185-T)
- Check the clearance between cams and pushrods.

- Remove
- The camshafts
- The pushrods and the capsules.
- Measure the thickness A of each capsule
- From amongst the capsules sold by the replacement parts, choose those that will give the correct clearance.

Clearance in practice

Inlet : 0.30-0.35 mm

Exhaust : 0.50-0.55 mm.

.012 .014
.020 .022

Thickness A = in steps of 0.025 mm

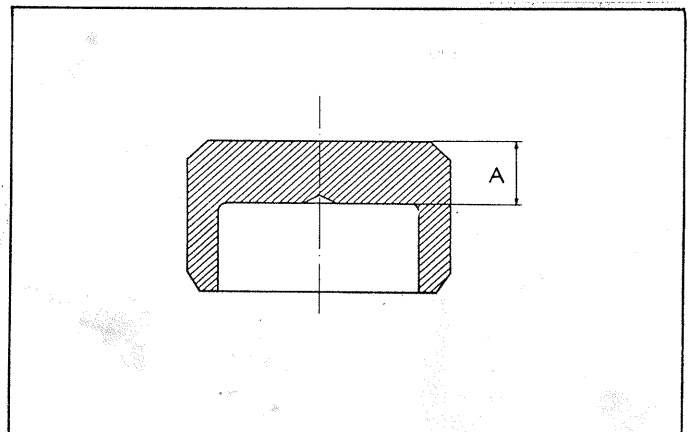
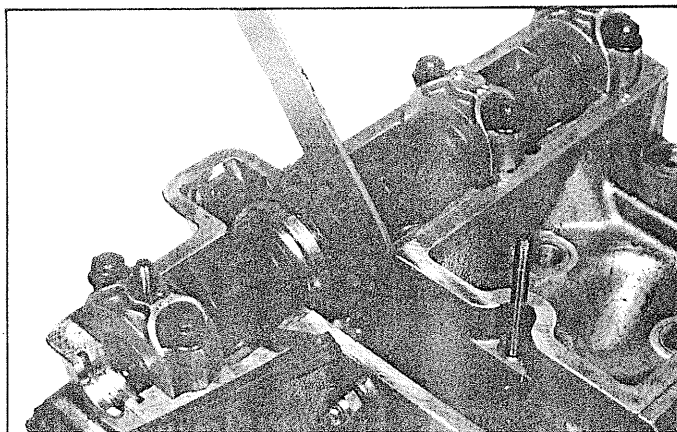

ASSEMBLY Contd.

37 Contd.

- Fit the capsules chosen in their respective places.
- Fit the pushrods.

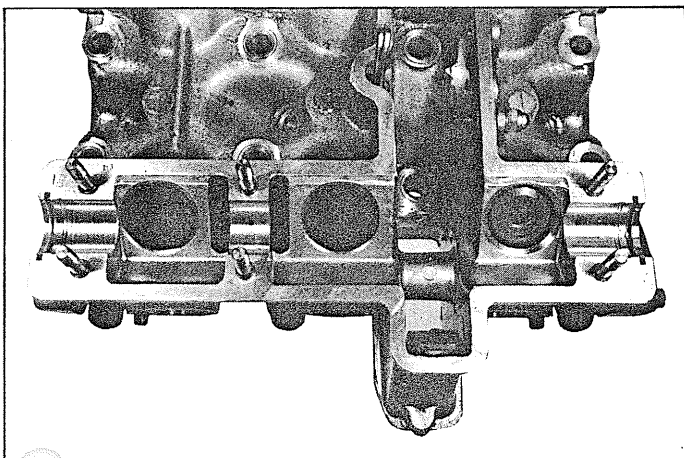

- Fit the camshafts
Tighten the bearing caps : 26-28 mAN
(2.6-2.8 m.kg, 18.8-20.3 ft/lbs)
- Turn the camshafts until the marks "a" and "b" are in line.

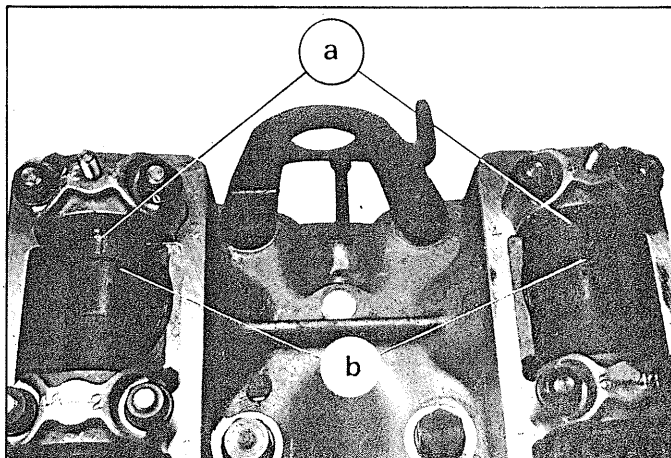

38

- Bring cylinder No. 1 to TDC
Mark "O" on intermediate shaft, visible in timing chain passage (straight edge support 1754-T and gauge 2437-T).
- Put the timing chain in position on the intermediate shaft (using wire) : the upper end of the chain should stand proud of the housing by approx. 200 mm.

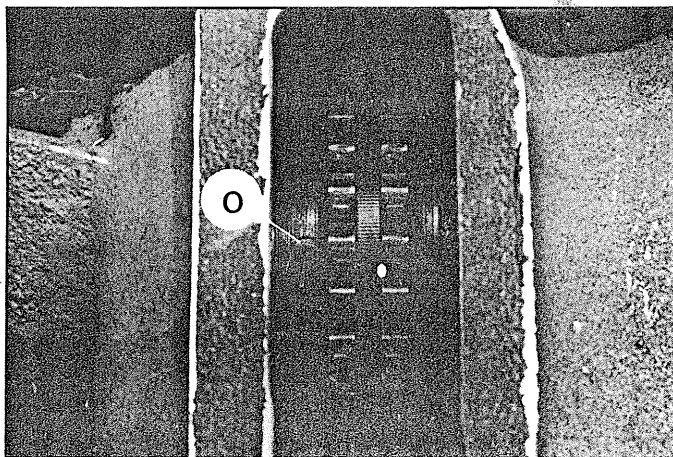
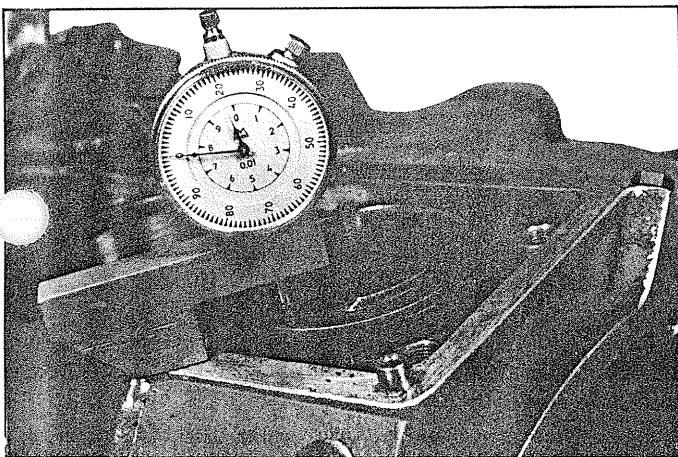

ASSEMBLY Contd.

PARTICULAR POINTS ON DISMANTLING AND ASSEMBLY

39

- Brass rings : (set of three) must not be pitted, scratched or cracked.
- (REINZ) gasket : there must be no burring at « a » and no hairline fractures.
- Fit the brass rings (1), slightly greased, on the barrels. Centre them.
- Place the REINZ gasket in position (correct any possible overlap).
- Fit the ring seals (2) in the holes « b ». *Primer 300 to hold in position*

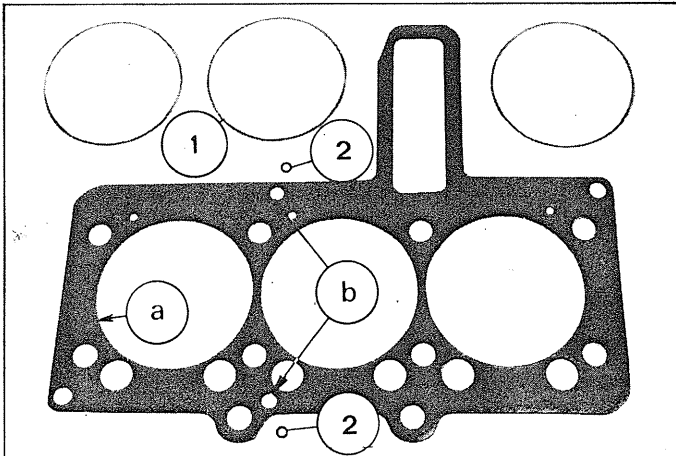

FITTING R.H. CYLINDER HEAD

- Fit the cylinder head on the block. Bring the two marks A and B into line.

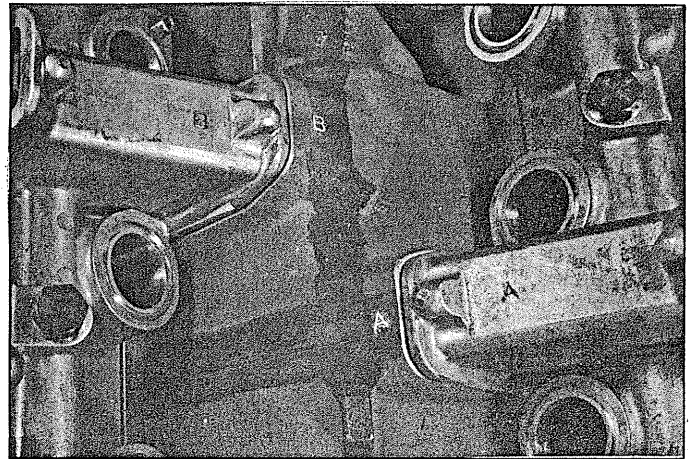

39 Contd.

FITTING R.H. CYLINDER HEAD

- Fit the cylinder head bolts in place (do not forget the lifting lugs).
- Tighten the bolts in the tightening sequence.
- 1st tightening : 50 mAN (5 m.kg 36 ft/lbs)
- 2nd tightening : 110 mAN (11 m.kg 79 ft/lbs)

- Fit the chain tensioner (ring seal on tensioner and copper washers under blind nuts). *(Align)*

- Pass the chain under the pinion of the exhaust camshaft.

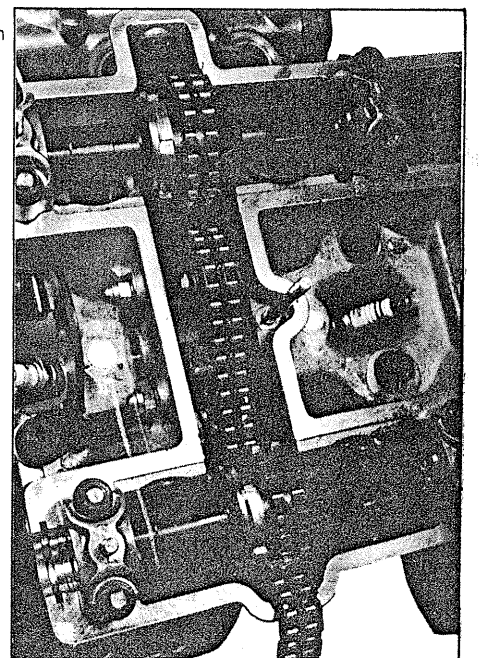
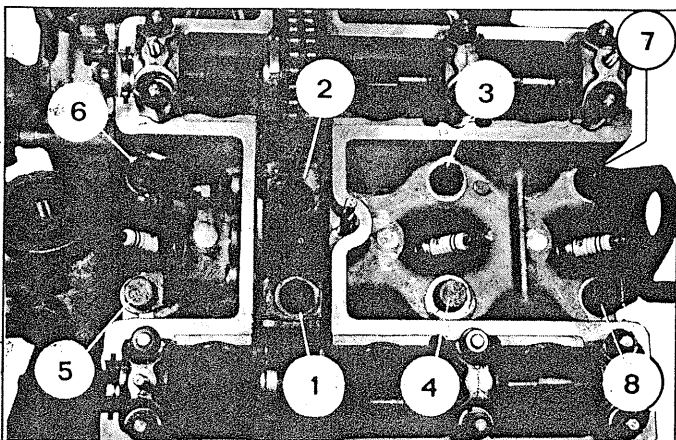

ASSEMBLY Contd.

39 Contd.

- Fit the spring link

- a) Thick spacer in middle of chain
- b) The clip on the side of the hexagonal camshaft adjusting nut
- c) Open end of clip towards rear (direction of chain rotation).

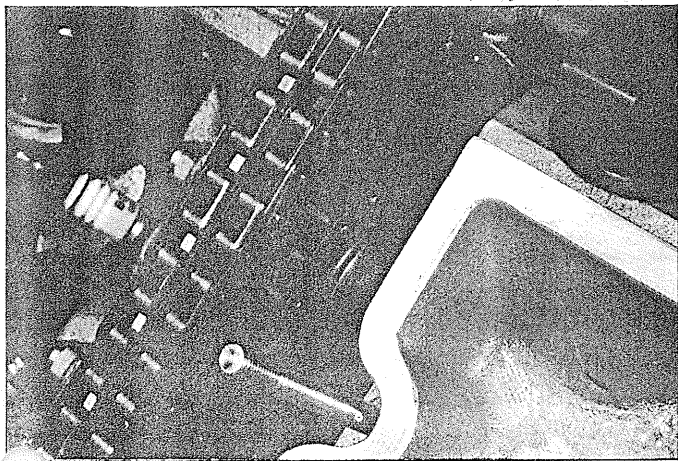
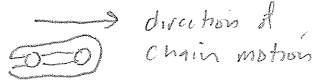

Tension the timing chain

20 mAN (2 m.kg 14.4 ft/lbs) i. e. 10 kg (22 lbs) on spring balance (Allen key 6 mm, extension MR 630-13/5 and spring balance).

Tighten the nuts (9) to 20 mAN (2 m.kg 14.4 ft/lbs).

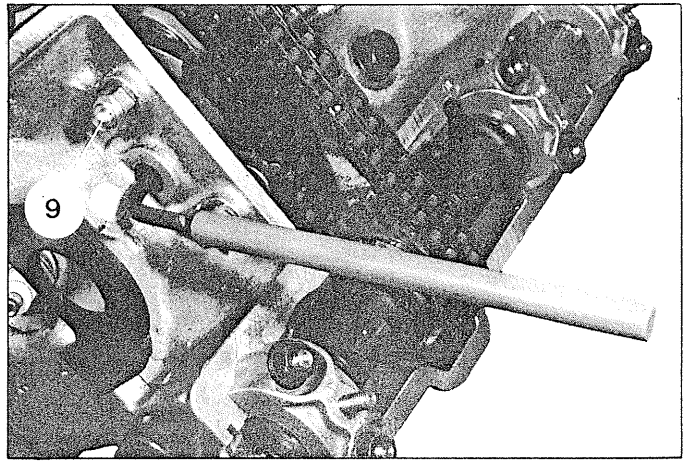

39 Contd.

TOOLS REQUIRED FOR CHECKING AND ADJUSTING THE TIMING (SET 3185-T)

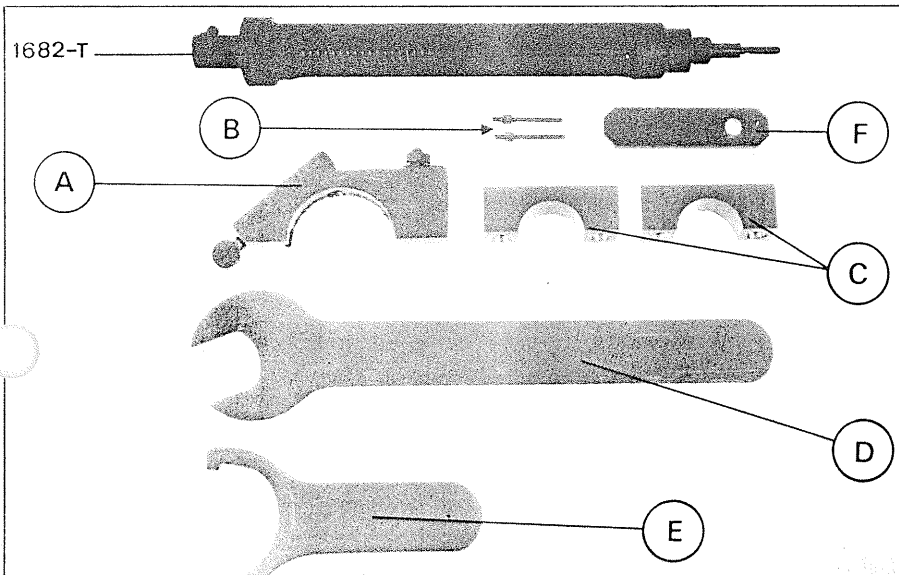

1682-T: Gauge support

- A : Gauge support
- B : Two gauge pins
- C : False bearings (*use strip of leather*)
- D : Spanner for turning camshafts
- E : Spanner for camshaft nuts
- F : Retaining plate for support A.

ASSEMBLY Contd.

PARTICULAR POINTS ON DISMANTLING AND ASSEMBLY

40

TIMING ADJUSTMENT (R.H. CYLINDER HEAD)

DISENGAGING CAMSHAFTS

- Loosen the nut (1) (pin spanner E of set 3185-T)
- Free toothed ring (2)

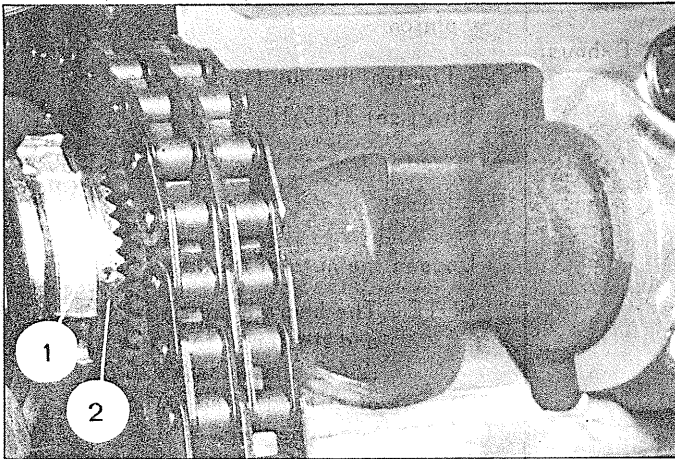

- Find top dead centre (TDC) of cylinder 1 (gauge support 1682-T gauge 2437-T)

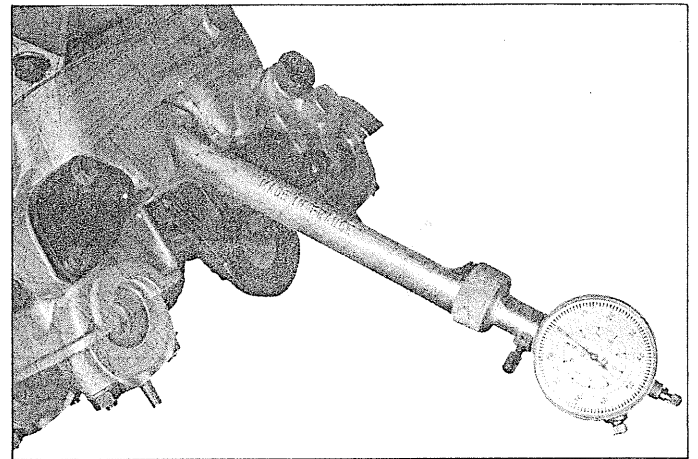

40 Contd.

- Replace the front bearings of the two crankshafts with the false bearings C of the set 3185-T.
- Do not tighten the nuts (3).

- Put the gauge support A from set 3185-T, and gauge 2437-T in position, with the pin pressing on the inlet pushrod of cylinder 1. Fix it in position using plate F from the set 3185-T

- Bring the needle of the gauge to 0.

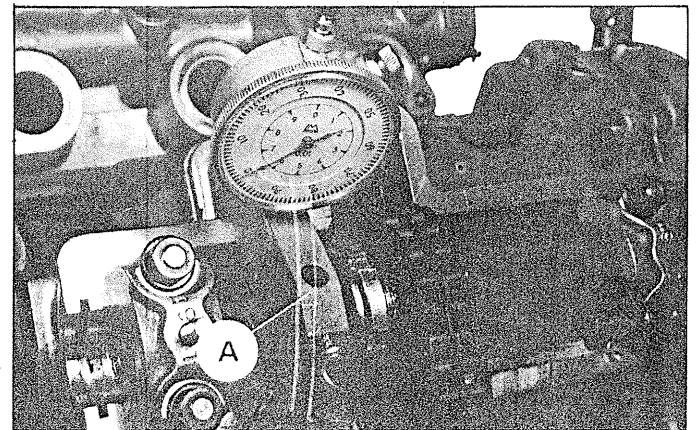
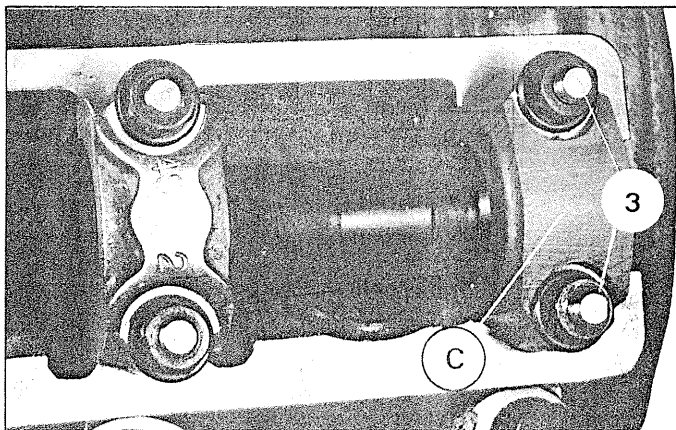

ASSEMBLY Contd.

40 Contd.

INLET

- Push in the pushrod by 1 mm, turn the camshaft in the rotation direction of the engine (spanner D from set 3185-T)
- Tighten the false bearing C of set 3185-T.

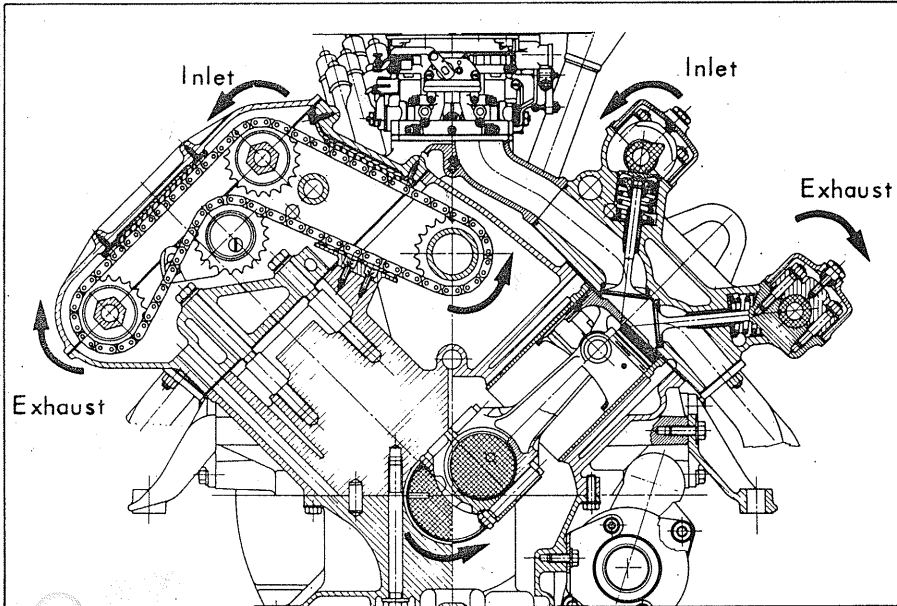

- Find, by turning the toothed ring (2), the point at which it engages at the same time in the splines of the camshaft and fully in the teeth of the pinion.
- Tighten the nut (1) (pin spanner E from set 3185-T).

Loosen the nuts of the false bearings.

NOTE : The bearing caps will be fitted and tightened to 26-28 mAN (2.6-2.8 m.kg 18.8-20.3 ft/lbs) after the timing adjustment has been checked.

40 Contd.

EXHAUST

- Fit the support A (fixed by plate F), the pin touching the exhaust pushrod of cylinder 1.
- Bring the needle of the gauge to 0
- Push in the pushrod by 1.3 mm : turn the camshaft in the opposite direction to that of the engine rotation.
- Tighten the false bearing C from set 3185-T.
- Find, by turning the toothed ring (2), the point where this engages correctly.
- Tighten the nut (1) (pin spanner E from set 3185-T).

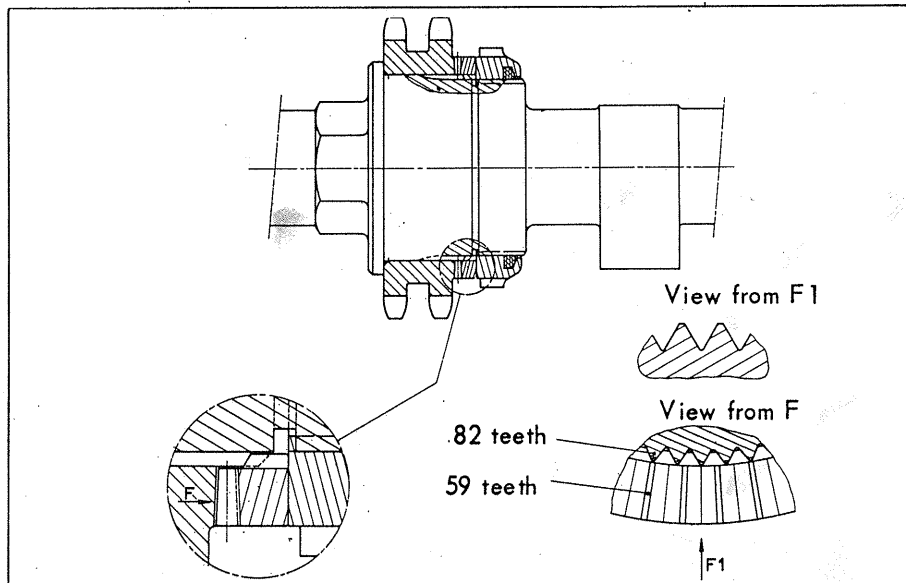

ASSEMBLY Contd.

PARTICULAR POINTS ON DISMANTLING AND ASSEMBLY

41

CHECKING TIMING ADJUSTMENT (R.H. CYLINDER HEAD)

USING MARKINGS

- With cylinder 1 at TDC and the valves in the "rocking" position, the long marks "a" on the camshafts must be in line with the marks "b" of the bearing caps.

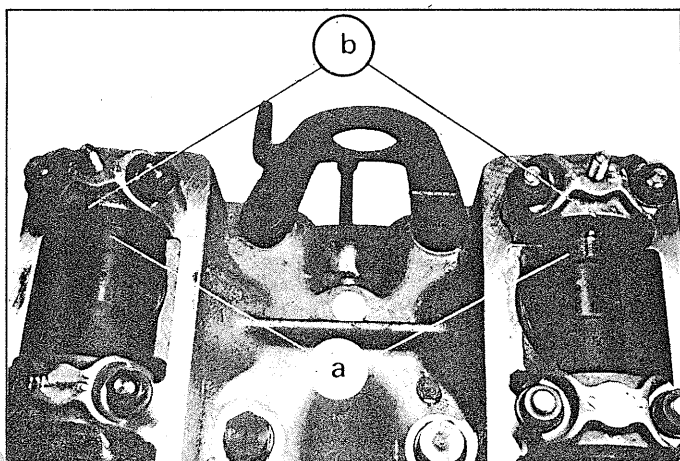

USING GAUGES

- Turn the engine in the opposite direction
- Bring the inlet cam of cylinder No. 1 to the position where the valve begins to open (however the pushrod must be able to rotate).
- Fit support A of set 3185-T in position
- Bring the needle to "0" (pin-pressing on pushrod)
- Bring cylinder 1 to TDC. The gauge of support A should show a travel of 1 mm.

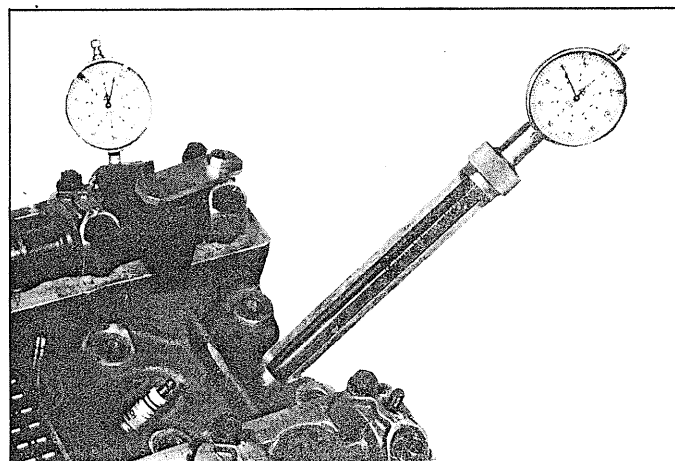

41 Contd.

- Fit support A in position on the exhaust pushrod of cylinder 1.
- Bring the needle to "0".
- Turn the engine until the valve is on its seat
- The gauge should show a travel of 1.3 mm.

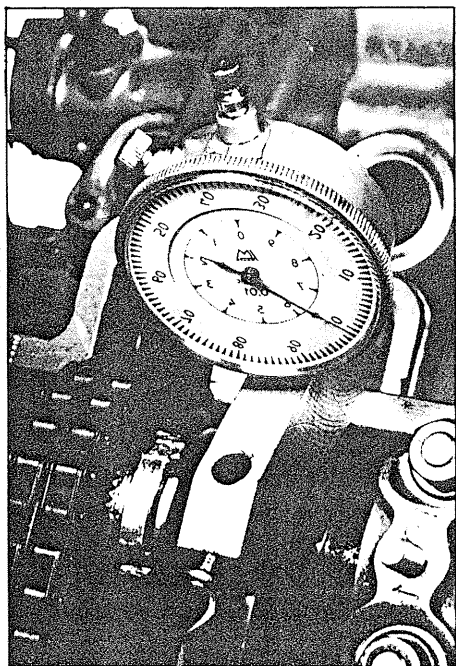

42

FITTING L.H. CYLINDER HEAD

- Bring piston of cylinder 6 to TDC (no mark "O" on shaft).
- Fit the timing chain on the intermediate shaft.
- Fit the brass rings and the cylinder head gasket in place.
- Fit the cylinder head and tighten to correct torque.
- Fit the chain tensioner and the chain
- Fit the spring link.
- Tension the timing chain.

ASSEMBLY Contd.

43

TIMING ADJUSTMENT (L. H. CYLINDER HEAD)

- Disengage the camshafts.
- Find TDC on cylinder 6
- Replace the bearing caps with the false bearings
- Fit gauge support A on the exhaust pushrod
- Bring the needle to "0"

Inlet : Push in the pushrod by 1 mm (direction of engine rotation)

- Tighten the false bearing
- Find the correct engagement point of the toothed ring.
- Tighten the nut

Exhaust : Fit support A in position on the exhaust pushrod

- Bring the needle to "0"
- Push in the pushrod by 1.3 mm (opposite direction to that of engine rotation)
- Tighten the false bearing
- Find the correct engagement point of the toothed ring.
- Tighten the nut.

44

CHECKING THE TIMING ADJUSTMENT (L.H. CYLINDER HEAD)

USING MARKS

- With the cylinder 6 at TDC and valves in "rocking" position, the short marks on the camshafts should be in line with the marks on the bearing caps.

USING GAUGES

Use the same procedure as that used when checking the timing adjustment of the R.H. cylinder head.

ASSEMBLY Contd

PARTICULAR POINTS ON DISMANTLING AND ASSEMBLY

45

STATIC DISTRIBUTOR ADJUSTMENT

- Bring cylinder 1 to TDC on the compression stroke
- Fit the distributor (cover removed)
 - 1) the bracket for the condensers approximately along central axis of engine
 - 2) the two dogs in the position shown below (see photo)

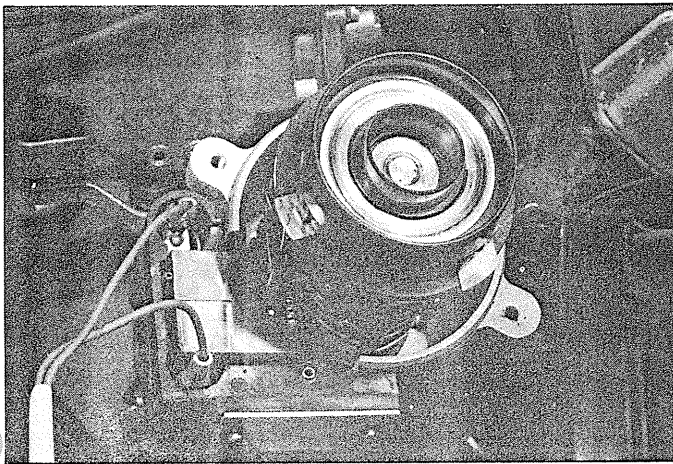
**46**

CYLINDER HEAD COVERS

- Fit the cylinder head covers
- Tighten the nuts to 10 - 12 mAN
(1-1.2 m.kg 7.2 - 8.7 ft/lbs)
- Fit the sparking plug wire brackets.

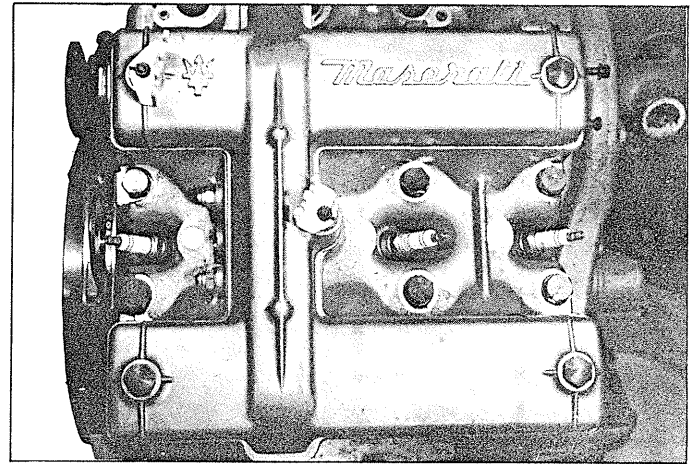
**47**

CLUTCH

- Fit the clutch disc and mechanism
(Centrer 3106-T or used control shaft).
- Tighten the securing bolts (1)
36-40 mAN (3.6 - 4 m.kg 26 - 29 ft/lbs)

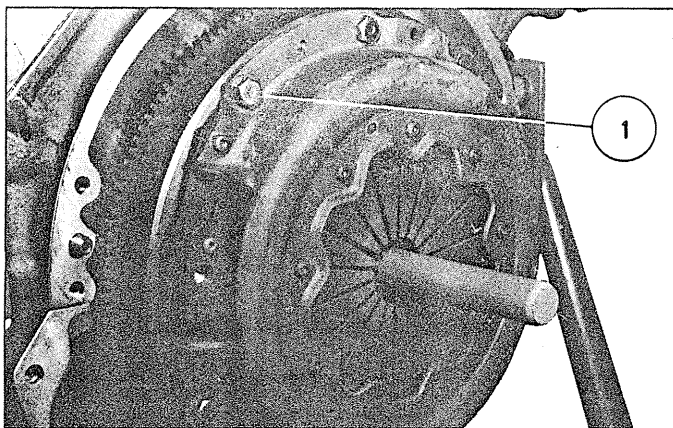
**48**

WATER MANIFOLD

- Fit the water manifold.
- Remove the thermostatic regulator, check it
Starts to open : 75° - 76° C (167° - 169° F)
Opening : 7.5mm minimum at 85° C (185° F)
- Fit the thermostatic regulator

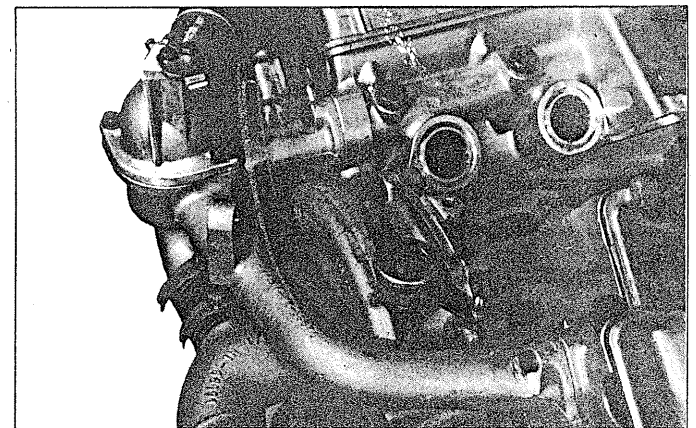

ASSEMBLY Contd.

49

- Fit the inlet pipe/carburetors assembly, tighten the bolt (1) : 5 m\N (0.5 m.kg 3.6 ft/lbs)
- Connect the accelerator control
- Fit the oil filler pipe, tighten the bolt : 20 m\N (2 m.kg 14.4 ft/lbs)

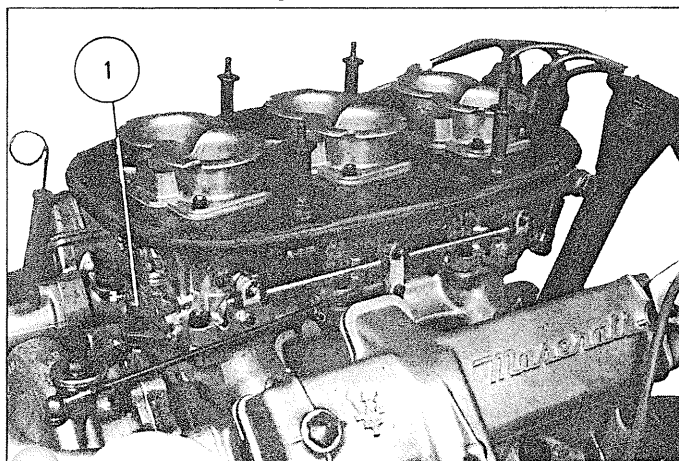

50

- Fit the oil filter (gasket oiled)
- Hand tighten it.

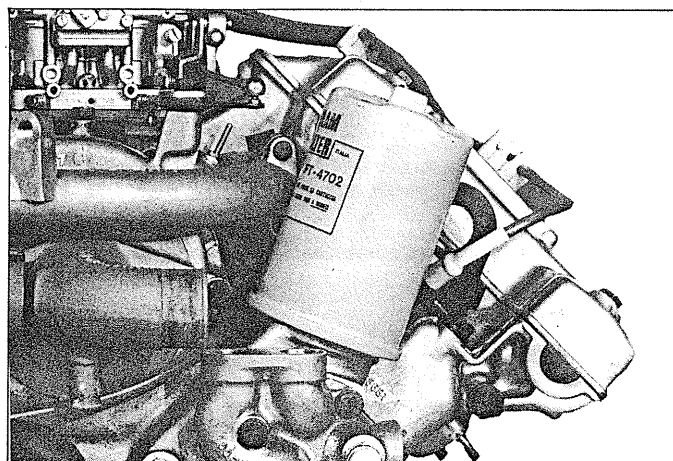

51

- Remove the engine from the support : Sling 2517-T

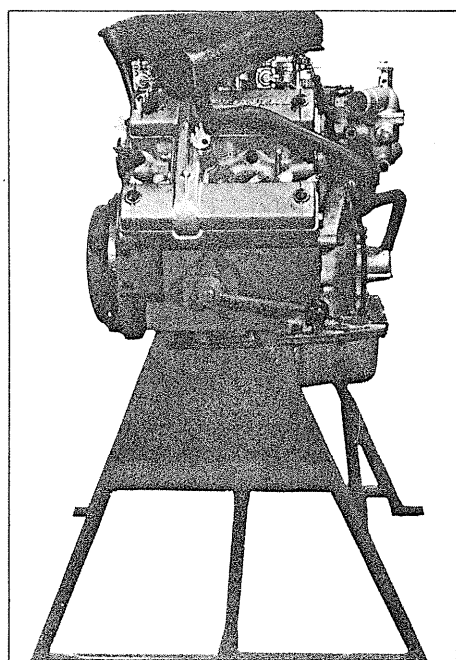

52

- Fit the starter motor (spanner 3061-T)
- Fit the engine supports and the rubber blocks
- Adjust them (measurement taken between bottom of steel support and the top of the rubber block).
- Tighten the engine support bolts 40 m\N (4 m.kg 29 ft/lbs)

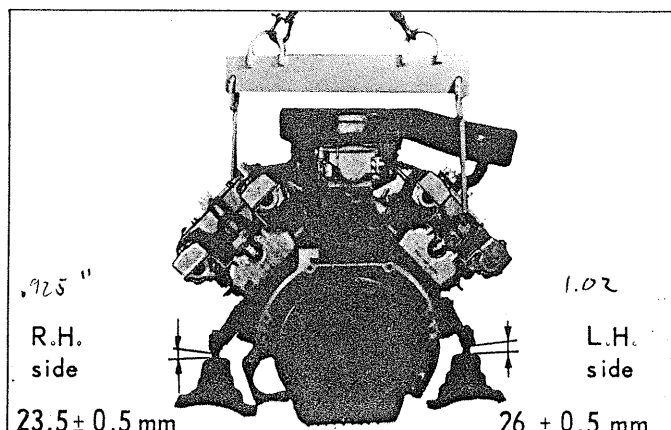

SPECIFICATIONS OF TOOLS NOT ON SALE

OIL SEAL FITTING TOOL

MR630.34/32

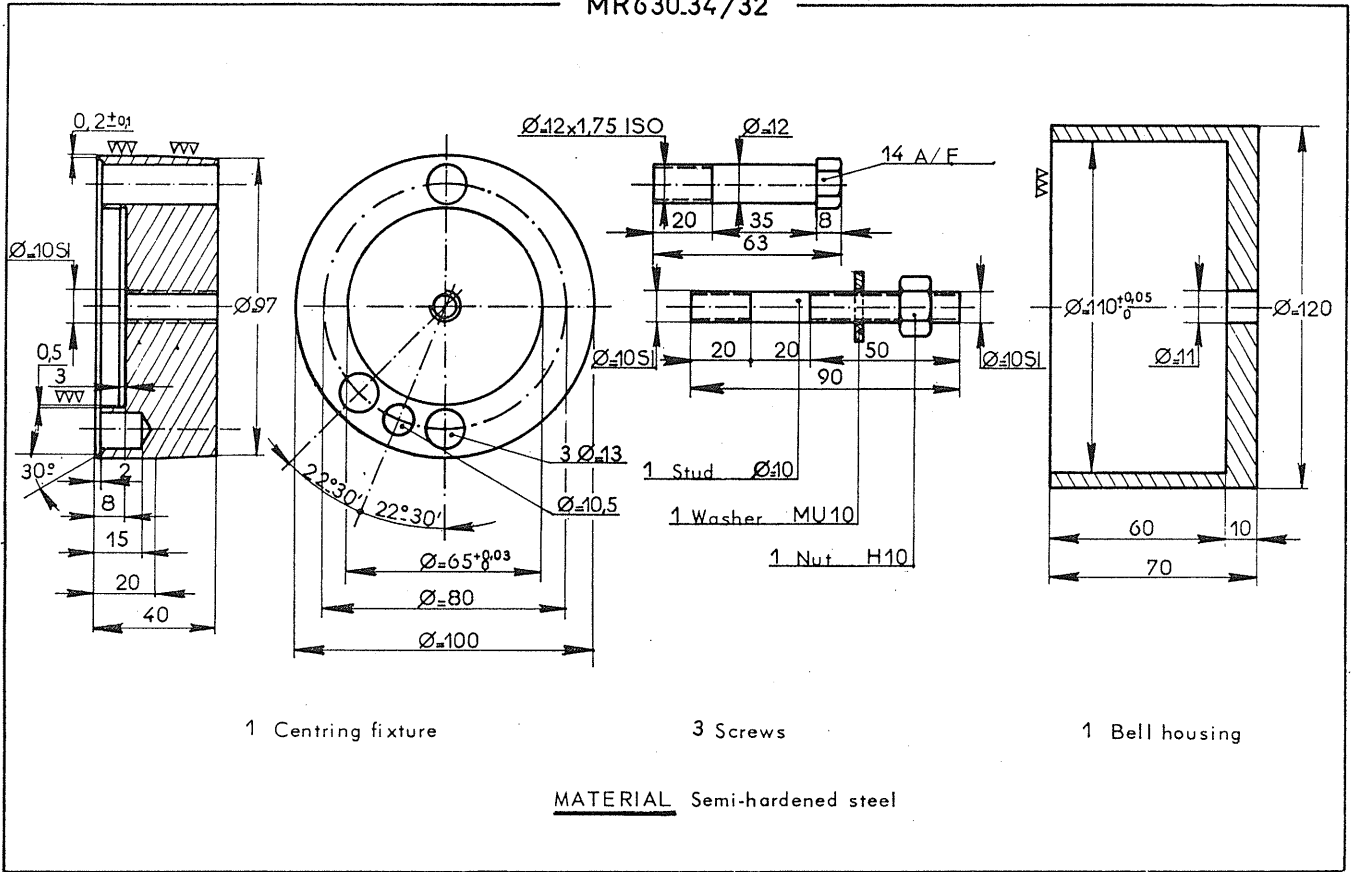

MR. 630-13 5

TIMING CHAIN TENSION

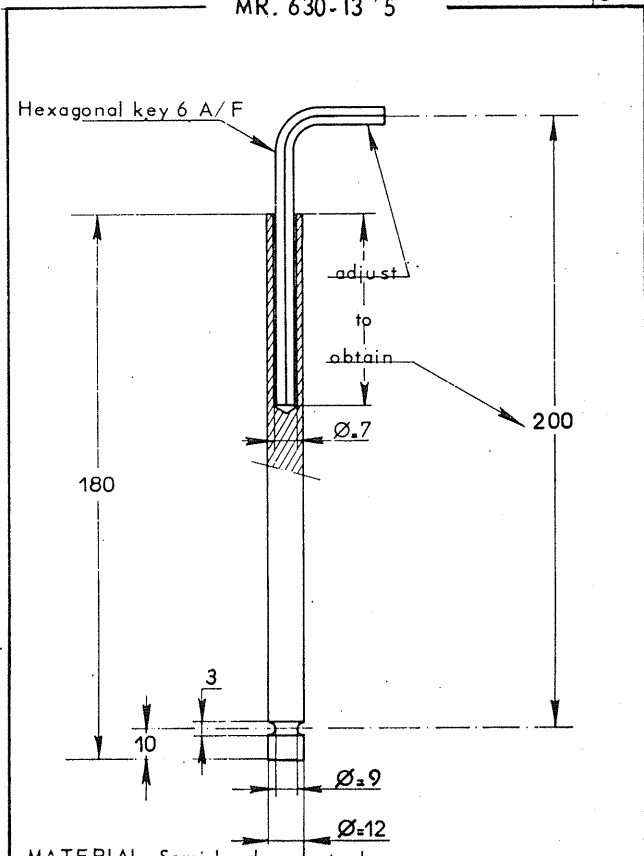

MR 630_14/49

OIL FILTER KEY

